

MAC Protocols with Wake-up Radio for Wireless Sensor Networks: A Review

Fatima Zahra Djiroun and Djamel Djenouri, Member IEEE/ACM

Abstract—The use of a low-power wake-up radio in wireless sensor networks is considered in this paper, where relevant medium access control solutions are studied. A variety of asynchronous wake-up MAC protocols have been proposed in the literature, which take advantage of integrating a second radio to the main one for waking it up. However, a complete and a comprehensive survey particularly on these protocols is missing in the literature. This paper aims at filling this gap, proposing a relevant taxonomy, and providing deep analysis and discussions. From both perspectives of energy efficiency and latency reduction, as well as their operation principles, state-of-the-art wake-up MAC protocols are grouped into three main categories: i) duty cycled wake-up MAC protocols, ii) non-cycled wake-up protocols, and iii) path reservation wake-up protocols. The first category includes two subcategories, i) static wake-up protocols vs. ii) traffic adaptive wake-up protocols. Non-cycled wake-up MAC protocols are again divided into two classes i) always-on wake-up protocol, and ii) radio-triggered wake-up protocols. The latter is in turn split into two subclasses: i) passive wake-up MAC protocols, vs. ii) ultra low power active wake-up MAC protocols. Two schemes could be identified for the last category, broadcast based wake-up vs. addressing based wake-up. All these classes are discussed and analyzed in this paper, and canonical protocols are investigated following the proposed taxonomy.

I. INTRODUCTION

Recently, wireless sensor networks have been attracting the research community and the industry with its large field of applications [1], [2] that ranges from enemy tracking in military [3], [4] to patient monitoring and health services [5], environment monitoring [6], animal tracking [7], security, business, smart cities [8], etc. Most of these applications in wireless sensor networks (WSN) need battery-powered nodes to be active for a long period of time without any human intervention after the initial deployment. In particular, sustainable long time operation without replacement is critical for those applications where sensor nodes are deployed in hostile and inaccessible environment. However, the small and the low complexity nature of the sensor nodes, as well

as of the batteries, makes this requirement a challenging problem. The period nodes operate before battery depletion replacement determines the network lifetime when battery replacement or recharging is impossible. A node that drains its battery (said to be dead node) reduces the communication and sensing coverage of the application, and when the number of dead nodes exceeds a certain threshold (e.g., to a certain degree that cause a network partitioning in the communication model), the network will not be considered operational anymore. Evaluations and experimental results indicate that the radio is the most energy consuming component [9]. The main reason of wasting energy in the radio is the use of idle listening. In this mode, the radio is listening to the channel without receiving or transmitting packets, but it consumes almost the same amount of energy as in the transmit or receive mode. For example, the TI/Chipcon CC2420 radio consumes 18.8 mA in idle mode, exactly the same amount as in receive mode [10]. Other studies have shown that more than 90% of energy is consumed only for monitoring the channel [11]. Therefore, idle mode is considered as a greedy source of energy waste in the node.

In addition to idle listening, there is another similar problem and source of energy wastage known as overhearing. Due to the shared nature of the medium, waiting for arriving traffic leads the sensor nodes to possibly receive irrelevant packets or signals that do not concern them [12]. The use of sleep mode and duty cycling the radio is the appealing solution to reduce energy wastage. The aim is to put the radio (and even the other components of the node) in the sleep mode for as long period as possible, and waking it up only when necessary, e.g., to exchange (transmit or receive) packets. However, a transmitter cannot transmit its packets when the targeted receiver node is in sleep mode. Switching to active mode at the right time to receive data is thus not obvious, since a sleeping node is not completely aware of what is happening in its vicinity, and it cannot always predict the coming traffic. A compromise consists to make a node alternating between active mode and sleep mode, which is known as duty cycling the radio. On the one hand, performing a low duty cycle, i.e. keeping the sensor node in the sleep state for most of time, saves energy but at the cost of increasing the waiting time at each hop. This rises the forwarding delay, which affects the end-to-end delay

Fatima Zahra Djiroun is with LRDSI Laboratory, Computer Science Department Saad Dahlab Blida 1 University, Algeria and CERIST Research Center, Algiers, Algeria

Email: djirounfz12@gmail.com

Djamel Djenouri is with CERIST Research Center, Algiers, Algeria

Email: ddjenouri@acm.org

(ACK)	ACKnowledgment
(AWD-MAC)	Asynchronous Wake-up on Demand MAC
(BACK)	Beacon ACKnowledgment
(BE)	BackOff
(BN)	Ban Node
(BNC)	Ban Network Controller
(CAT)	Channel Assignment Table
(CAP)	Channel Assignment Packet
(CCA)	Clear Channel Assessment
(CCC)	Common Control Channel
(CDMA)	Code Division Multiple Access
(CFP)	Contention Free Period
(CMOS)	Complementary Metal Oxide Semiconductor
(CPU)	Central Processing Unit
(CSMA)	Carrier Sensing Multiple Access
(CTS)	Clear To Send
(EH-WISP-MOTE)	Energy Harvesting Wireless Identification and Sensing Platform MOTE
(FDMA)	Frequency Division Multiple Access
(GAF)	Geographic Adaptive Fidelity
(GTS)	Guaranteed Time Slot
(IBSN)	Implantable Body Sensor network
(LECIM)	Low Energy Critical Infrastructure Monitoring
(LMP)	Low Power Mode
(LPR)	Low Power Rendez-vous
(MAC)	Medium Access Control
(MCU)	Micro-Controller Unit
(MELM)	Minimum Energy and Latency MAC
(MFP)	Micro-Frame Preambles
(OOK)	On-off keying
(PCB)	Printed Circuit Board
(PDR)	Packet Delivery Ratio
(PER)	Packet Error Rate
(REACH-Mote)	Range EnhAnCing energy Harvester-Mote
(REQ)	REQuest
(RTS)	Request To Send
(RTWAC)	Radio-triggered wake-ups with addressing capabilities
(SCM-WuR)	SubCarrier Modulation Wake-up Radio
(SFB)	Start Frame Bit
(STEM)	Sparse Topology and Energy Management
(STEM-B)	Sparse Topology and Energy Management Beacon
(STEM-T)	Sparse Topology and Energy Management Tone
(SpA-WuRx)	Wake-up receiver
(TDMA)	Time Division Multiple Access
(UHF RFID)	Ultra High Frequency Radio Frequency IDentification
(UWB)	Ultra-Wide Band
(WB)	Wake-up Beacon
(WBAN)	Wireless Body Area Network
(WSN)	Wireless Sensor Network
(WuCs)	Wake-up Calls
(WuRx)	Wake-up receiver
(WuTx)	Wake-up Transmitter

Table I: List of Acronyms

(latency). On the other hand, a higher duty cycle can respond to traffic conditions and network changes more quickly, but at the cost of consuming a large amount of energy as the sensor node stays active for a long period of time. Moreover, idle listening and overhearing remain an issue with duty-cycled MAC protocols, since nodes still wake up periodically to check the channel. To reduce channel checking drawbacks, many duty-cycled MAC protocols introduce synchronization among the nodes. Nevertheless, this necessitates a large number of overhead packet exchange, which is considered as a another source of energy dissipation. Several approaches have been explored to mitigate this problem such as the use of cognitive radio [13], or spatial scheduling that mitigates effects of collisions [14], and the introduction of energy harvesting mechanisms [15], [16], [17].

While earlier solutions (such as duty cycled MAC protocols) have been focusing on energy saving as a unique goal, quick progress in technology has conducted to the emergence of new real-time applications for which delay is of immense priority. This makes earlier energy-only solutions ineffectual. Some recent solutions consider multi-objective optimization where both energy consumption and latency are balanced. Examples of such solutions include MAC protocols [18], routing protocols [19], etc.

An alternative solution is to endow the main radio with an additional low power wake-up radio responsible for waking it up only when there is a packet to receive. This enables the main radio to go to deep sleep as long as there is no transmission intended for it. This eliminates idle listening and achieves more energy saving, while accelerating packet forwarding by eliminating waiting time at each hop. Furthermore, this alternative is asynchronous and does not require time synchronization. Moreover, overhearing is reduced, and even eliminated with the addressing capability of current wake-up radios systems where only nodes concerned by the communication are awoken. The use of a wake-up radio reduces collisions between data and wake-up messages and allows simultaneous exchange of these messages (since they are transmitted in different channels). These features have been motivating the research community to investigate the use of wake-up radio [20], [21]. Consequently, many MAC protocols using wake-up radio have been proposed. However, we realize that there is a lack in the current literature of a comprehensive review of this category of MAC protocols. This paper reviews state-of-the-art MAC protocols using wake-up radio in WSNs. It presents a new taxonomy and a comparative study of the literature from the perspectives of both delay and energy. Note that we focus on protocol and communication aspects of wake-up MAC protocols, while security and reliability are beyond the subject of this paper.

The reminder of the paper is structured as follow: Sec.II gives an overview of related work.

Sec.III presents some hardware solutions of WSN wake-up radios and discusses their performances. In Sec.IV, a short review of previous MAC protocols are presented, followed by a description of the proposed taxonomy. The different classes of the proposed taxonomy are presented from Sec.V through Sec.VII. A discussion and analysis of all the presented classes is given in Sec.VIII. Finally, the conclusion is drawn in Sec.IX.

II. RELATED WORK

MAC protocols for WSNs have been largely investigated. Bachir et al. [22] provide a general review on a large number of existing WSN MAC protocols, where Doudou et al. [18] focus on asynchronous MAC protocols targeting the timeliness issue. These surveys, as well as some other ones such as [23], [24], etc., targeted MAC protocols that duty cycle a single radio. Integrating and controlling a wake-up radio beside the main radio have been considered in several applications [25], [26]. Few review papers briefly report the use of a wake-up radio in WSNs such as [27], [28] and [29]. The latter presents some canonical MAC protocols using wake-up radio. It considers these protocols as a general subclass of WSNs' MAC protocol. Some works have only focused on evaluating the wake-up receiver hardware [30], while others have compared some duty cycled MAC protocols and those using a wake-up radio [31]. In [27], the authors termed wake-up radio MAC protocols as purely asynchronous MAC protocols, and they consider them as a new rendez-vous scheme in wireless sensor networks. However, their study was limited to high abstracted descriptions and some limited comparisons. It has been concluded that the purely asynchronous scheme is preferred over the pseudo-synchronous schemes, when the WURx consumes less than $50\mu W$, which is feasible. Anastasi et al. [29] consider that MAC protocols using wake-up radio are on-demand schemes that represent a subclass from sleep/wakeup protocols. Carrano et al. [28] focus on duty cycled MAC protocols. Similar to [29], they treat wake-up MAC protocols as on demand protocols and present only one solution. The contribution of the present paper compared to [29] and [28] is to review what they considered as a single class (on demand MAC protocols) and divide it into subclasses. Demirkol et al. in [32] concentrate on solutions with a second (wake-up) radio, where some hardware solutions are presented and some canonical MAC protocols are briefly described. Their description was organized following the power source of the wake-up radio around two parts: i) protocols using active wake-up receivers (use the battery to wake-up the main radio), and ii) protocols using passive wake-up receivers (use the energy of the wake-up signal). They pass into review a few number of wake-up MAC protocols without any taxonomy of this category of MAC protocols. The paper focuses mostly on the benefits and

challenges of wake-up receivers, and it presents some applications and different trade-offs. The paper did not discuss several works available in their period, such as [33], [34], [35], [36], [26] and [37], in addition to those published later, e.g., [38] and [39].

An analytical model that facilitates to match a wake-up scheme to an application scenario has been proposed in [31], where the latency has been considered as the main constraint. A comparison between MAC protocol using a wake-up receiver with X-MAC [40] and TDMA protocol has been presented in [41], where analytical models for the wake-up receiver's power budget has been derived. Another comparison between a representative wake-up receiver and a general preamble sampling scheme has been presented in [42]. Authors discuss the feasibility of employing a wake-up receiver under its high sensitivity in comparison to commercial radio chips. A comparative study of existing wake-up receiver prototypes has been presented in [30]. The authors consider two kinds of wake-up radio: i) WUR, that receives and transmits the wake-up signal, ii) and WURx, that only receives the wake-up signal. Results have proved the advantages of using WURx mainly for more prolonged lifetime compared to duty cycled based schemes. The analysis focuses only on evaluating the hardware performances and the addressing capabilities, using some mathematical models that have been derived in the literature. SCM-WuR hardware [43] has been evaluated in [44] and compared with B-MAC [45] and basic IEEE 802.15.4 [46]. Experimentation results shown that SCM-WuR achieves high energy efficiency with lower latency and very satisfactory PDR. Authors realize that wake-up receiver based schemes outperform conventional MAC protocols. A mathematical model for energy consumption has been developed in [47]. Using this model, an RFID Impulse -an example of a very low power wake-up radio scheme- has been compared with DMAC [48] and IEEE 802.15.4 MAC [46] protocols. Experimentations show that RFID Impulse is more energy efficient. A brief study of a number of power management techniques for WSNs with wake-up radio is presented in [49], where the authors review several architectures destined to optimize energy consumption in WSNs, at the physical level. They focus on the combination of power minimization techniques with recent technologies based on wake-up receiver or energy harvester. However, their analysis was restricted to the hardware description and the presentation of the advantages that could bring this combination in terms of reducing energy consumption and lifetime extension. On contrary, our study focuses on the MAC layer. The contribution consists in providing a new taxonomy and classifying the existing MAC protocols that are based on wake-up radio on different categories.

Authors in [50] provide an analysis of different duty cycled wake-up receivers including the WB (wake-up beacon) structure, the front end, and the digital base-

band design. A short analysis of three MAC protocols with wake-up radio has been introduced in [51]. The investigated MAC protocols are destined to Implantable Body Sensor Network (IBSN). Most existing surveys and position papers focused on the analysis and evaluation of the wake-up receiver and motivate its employment. A complete and a comprehensive study of wake-up radio based MAC protocol in WSN is missing in the current literature. More precisely, there is no survey paper reviewing MAC protocols with wake-up radio. The few existing papers consider them in only a single class. In this paper, we provide a comprehensive study of the state-of-the-art MAC protocols that use a wake-up radio. We covered the literature from early 2000 up to *March*2016. Different from previous works, our main contribution is to survey the relevant state-of-the-art and to split what has been considered as a single class into several different subclasses. A comprehensive taxonomy is provided based on the energy saving and latency improvement of the wake-up radio, and a comparative evaluation is presented. It should be mentioned that our taxonomy is built on the wake-up channel behaviour, contrarily to the existing survey papers which are based on the main channel policy. To our knowledge, this is the first survey paper of the *wake-up* radio MAC protocols. A brief summary of the survey papers that exist in the literature is presented in Tab.II.

III. WAKE-UP RADIO HARDWARE

Power management schemes attempt to control the transition time of the node between active mode and sleep mode, in way that guarantees low energy consumption along with reduced latency. While switching from high power to low power is evident, the inverse is complicated as the node's CPU is turned off and thus the node could not be aware of when the reception could occur. Always listening to the medium or duty cycling are two known schemes that have been widely used. The first one ensures an efficient data forwarding but with high energy consumption, while the second reduces energy consumption but at the cost of an increased latency. Some duty cycle schemes require time synchronization among the network nodes. Due to the instable communication links and the low computation capacity of the nodes, as well as the fast clock drift of the sensor motes, synchronization becomes an energy consuming task [52]. To cope with synchronization disadvantages, other duty cycle schemes use low power listening mode, but this has also the cost of energy dissipation and high end-to-end delay. The alternative considered in this paper is to use an additional low power wake-up hardware device (component) to listen to the medium while the node is in sleep mode. The wake-up radio is capable of immediately reacting to an external event, waking up the node that is in sleep mode, performing low energy consumption, and guaranteeing good forwarding delay.

Previous Survey papers	Discussed topics	Contribution of the current paper
[22], [24]	A large field of WSN MAC protocols using a single radio have been reviewed and classified	A specific category of MAC protocols that are based on a wake-up radio have been reviewed and classified
[18], [23]	A reduced field of MAC protocols have been organized in different classes without focusing on wake-up MAC protocols.	The focuses was only on MAC protocols using wake-up radio
[27], [29], [28]	Wake-up MAC protocols have been considered as a single class	Wake-up MAC protocols using wake-up radio have been divided in several classes
[30], [44], [49], [50]	Evaluation of the wake-up receiver hardware is presented	A study of some wake-up receiver hardware and a deep analysis with a new taxonomy of wake-up MAC protocols (software level)
[31], [47]	Analytical models are provided	A review of state-of-the-art MAC protocols using wake-up radio for WSNs
[32]	Magazin paper about wake-up MAC protocols	A deep study of the state-of-the-art on MAC protocols that are based on a wake-up radio, providing a new taxonomy and a comparative evaluation
[41], [42], [43]	Comparison between one radio based MAC protocols and wake-up MAC protocols	A comprehensive study wake-up radio based MAC protocols
[51]	Evaluation of some wake-up MAC protocols	Evaluation and a comparative study of all the wake-up MAC protocols proposed thus far

Table II: Summary of existing survey papers and their discussed topics

Two types of wake-up radios have been developed in the literature, active and passive. Active wake-up radios are characterized by a long wake-up range, as they use sufficient amount of energy from a battery. Passive wake-up radios are powered with the energy from the wake-up signal, without requiring a battery. Nevertheless, their wake-up range is shorter compared to active wake-up radios' range. Some solutions have combined the two schemes to improve the performances of both energy and wake-up range. From this point of view, the most relevant wake-up circuits are split into three classes. An overview of these classes is presented in the next subsections, while all the presented wake-up circuits are summarized in table III.

A. Active Wake-up Radios

In this section, wake-up radios that are based on the use of the battery power are presented. Earlier solutions consist of using a second low power radio that is always-on as a wake-up radio. PicoRadio [53], [54], is an example of a very low power always-active transceiver. It can be used either alone as a main radio on the sensor node, or as a wake-up radio. The proposed module can reach an indoor communication range of $20m$, consuming $1.6mW$ in transmit mode and $380\mu W$ in receive mode at $1V$ of supply voltage, with a receiver sensitivity of $-75dBm$.

In [55] a low power wake-up radio destined for WBAN has been designed and presented. The wake-up radio is always-on with an ultra low power consumption of $470nW$ at a voltage value of $2V$. Its main components are a charge pump that is used to detect the received OOK signal. A comparator is then responsible for correcting and forming the bit sequence of the received packet. The latter will be delegated to a preamble detector to exclude unnecessary wake-ups from common interference sources. If the received preamble sequence is correct, a second comparator should generates the wake-up signal. An enhancement of the same work has been presented in [56] where the authors have diminished the energy consumption of the circuit to $270nW$.

A different wake-up receiver has been proposed in [57]. The scheme provides two different mechanisms for wake-up packet reception and processing. In monitoring mode (MO), the wake-up receiver adopts a bit-level duty cycle scheme to receive the start frame bits (SFBs) of the wake-up packet, which are transmitted at a low data rate ($1kbps$). Once the SFB sequence is detected, the wake-up receiver stops duty cycling and switches to identification mode (ID), in which a higher data rate of $200kbps$ is adopted to receive the rest of the data. The proposed scheme operates in the $902 - 928MHz$ frequency range,

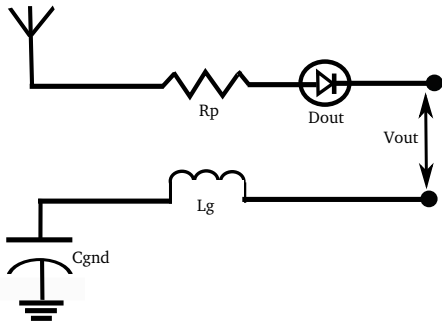

Figure 1: Basic radio-triggered circuit [59]

and it has an average power consumption of $8.5\mu W$ at $1.8V$ supply in MO mode and $1.1mW$ in ID mode. However, it is prone to a non negligible latency due to duty cycle adoption. Note that the maximum wake-up range has not been reported.

B. Passive Wake-up Radios

In this section, wake-up radios that make only use of the wake-up signal power are described.

In [58] and [59]. A passive radio-triggered circuit has been developed and connected to one of the interrupt inputs of the processor in the node. The circuit (see fig. 1) does not require any power supply. It extracts energy from the wake-up signal to trigger the interrupt of the micro controller, which wakes up the main radio of the node. This idea is similar to that used in passive Radio Frequency Identification (RFID) systems. Furthermore, the wake-up process is selective, i.e., a node does not wake up unless a wake-up signal at its assigned radio frequency is present. Results have shown an important improvement in energy saving which is about 70%, to 98%, compared to duty cycled, and always-on schemes, respectively. The maximum achievable wake-up distance of the basic radio-triggered circuit was 3 m, and some enhancements have extended it up to 9 m, by adding some low power components to the circuit operating with ultra low power current consumption (between $350nA$ and $880nA$), at the cost of minor increase of the latency (from $2.8ms$ to $5ms$). However, the addressing mechanism necessitates a different frequency for every single node, which requires an additional hardware per frequency.

A battery-free platform for sensing and computation (called WISP) has been developed by Sample et al. in [60]. WISP is the first fully programmable platform, playing the role of an enhanced passive RFID tag that integrates a $16bit$, general-purpose microcontroller as part of a passive UHF RFID tag. It is also incorporated in it, different low power sensors such as light, temperature, etc. WISP can operate using only energy harvested from the signal transmitted by an UHF RFID reader, achieving a distance of $4.5m$. When a query is received, the tag communicates the desired sensor data

encoded in its ID. When this latter is received by the reader, it will announces (reports) it to the application software in order to extract and interpret the information included in it. The passive tag has been integrated with Tmote Sky mote in [61] as a wake-up radio. WISP can reach a distance up to $4.5m$. Combining it with Tmote sky, WISP-to-reader communication can be disabled, extending thus the wake-up range to about $5m$. Given this limited range, WISP-motes have been used with mobile sinks to cover a wide area. Each sink is equipped with an RFID reader that wakes up the WISP-mote when it enters its communication range, and collects buffered data from it. Both broadcast-based wake-up and ID-based wake-up are supported by the WISP-mote. To improve the wake-up range, an energy harvesting circuit [62] has been combined with the WISP-mote in [63]. The proposed circuit (EH-WISP-Mote) extends the wake-up range to about 20% over WISP-mote, while maintaining ID-based wake-up capabilities. Both the WISP-Mote and the EH-WISP-Mote use the MCU on the WISP circuit to trigger the Tmote Sky's microcontroller. Although the WISP's MCU consumes $250\mu A$ at $2.2V$ power supply, it is considered highly energy consuming compared to the very limited amount of the harvested energy. Therefore, another circuit has been developed to wake up the microcontroller with lower energy consumption. The latter has been integrated with the energy harvesting circuit [62] on the Tmote sky. The resulted circuit, REACH-Mote, extends the wake-up range to 11 m. However, it suffers from a high wake-up latency. For example, at a distance of 1.5 m, the average delay is of $235ms$.

RFIDimpulse [36] is another fully passive solution that consists of attaching an RFID reader and tag to each mote. When a node wants to transmit a packet, it wakes up its neighbor by transmitting a wake-up signal using its RFID reader. The receiver's tag captures the electromagnetic waves and generate a voltage of $0.5/0.6V$ as an interrupt to the sensor MCU, which in turn wakes up the main radio to start data transmission. However, it is not possible to absorb all the energy received at the tag. This results in some energy reflection known as back scattering phenomenon. Unfortunately, this phenomenon, in addition to the passive nature of the RFID tag, may significantly affect the wake-up range. Furthermore, a non negligible amount of time is spent in waking up the MCU and the main radio, $128\mu sec$ and $2.4msec$, respectively.

C. Hybrid Wake-up Radios

To cope with the wake-up range limitation in passive wake-up circuits and the high energy consumption of the active wake-up circuits, some hybrid solutions have been proposed. Wake-up radios that combine the use of the battery power with the energy from the signal are presented in this section.

Malinowski et al. developed a direct amplifying RF

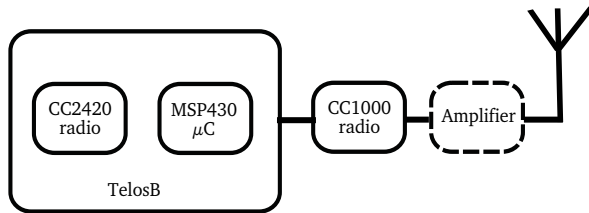

Figure 2: RTWAC's wake-up transmitter part [67]

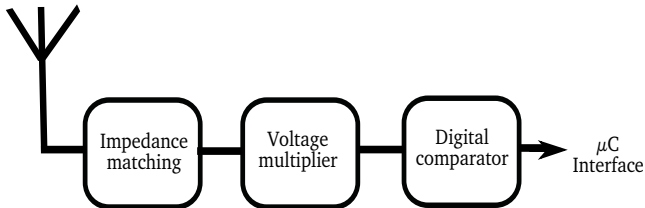

Figure 3: RTWAC's wake-up receiver part [67]

tag, operating at $300MHz$ as a part of the CargoNet project [64]. Contrary to RFIDimpulse, in this scheme the node is only equipped with this tag, while the CargoNet system is equipped with a single reader that interrogates the different tags of the nodes. The main building blocks of this RF detector are antenna matching network, envelope detector, and micropower amplifier. The receiver sensitivity and power consumption of the circuit are $-65dBm$ and $2.8\mu W$, respectively. The RF detector is able to detect an On-Off-Keying (OOK) signal modulated with baseband square pulses of $25Hz$ at a maximum range of $8m$.

A semi passive wake-up circuit has been proposed by Kolinko et al. in [65]. The proposed circuit operates in $916MHz$ frequency band and can reach a range of $213m$ with $+30dBm$ wake-up transmitter, consuming $20\mu W$ of energy.

An ultra low power wake-up radio has been designed in [66]. An address decoder and a RF detector are included in the device. The circuit is realized to operate in $2.4GHz$ frequency band with an energy consumption of $20\mu W$ at $50kbps$ of data rate. The wake-up range has not been investigated.

Ansari et al. have developed another wake-up circuit named (RTWAC) [67]. The circuit, which includes the transmitter (fig. 2) and the receiver (fig. 3) parts, can reach a distance of $7.5m$, with the capability of selectively wake up. Experimentations have indicated a significant energy saving and a very low latency vs. BMAC (duty cycled scheme). However, a node's micro controller still wakes up when detecting a wake-up signal that is not destined to it. Moreover, the mean packet receive error ratio was 10%.

Recent advancement in micro-electronics makes it possible to perform the addressing and decoding without waking the microcontroller. This has been used in [68], where a low frequency has been modulated in a high one

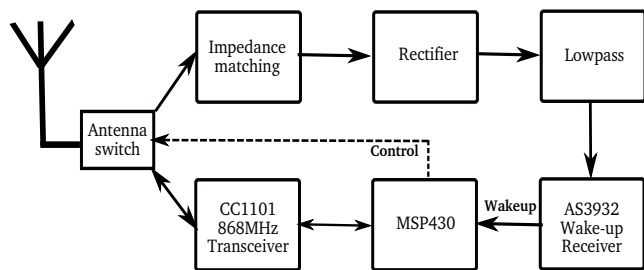

Figure 4: Node architecture integrating a wake-up receiver block [68]

to reduce power consumption while avoiding increasing the antenna size. The wake-up signal is selective and uses a $16bit$ address coding. It is transmitted by the main radio, and received by a passive demodulation scheme (fig. 4). The latter is responsible of impedance matching, rectifying and low pass filtering the received signal, which will be fed to the wake-up receiver. When perceiving a valid wake-up signal address, the wake-up receiver interrupts the micro controller which will toggle the antenna switch and allow the main radio to start data communication. The circuit consumes about $2.78\mu A$ of current. This includes energy consumption of both the micro controller and the main radio. It allows a wake-up distance of about $40m$ with $+10dBm$ as an output power level in the transmitter. Experimentations have indicated that a node could have a theoretical lifespan of 8 years when powered by a CR2032 coin cell. The authors propose another version of the radio in [43] with an increase in the current to $3.5\mu A$ for an improved wake-up range, up to $90m$. It has been applied in a star topology and intended to a single hop network, where the host node (the sink) is supposed to have an infinite power source that allow it to reach all the nodes in one hop.

Another radio-triggered wake-up circuit (fig. 5) with a very low energy consumption of $8.7\mu W$, has been proposed by Sanchez et al. in [69]. To reduce the cost and the size, the circuit is designed using only CMOS elements. It is flexible and can operate at $433MHz$, $868MHz$ or $2.4GHz$ bands. The wake-up signal is made selective without the help of the micro controller. It is transmitted by the main radio after having adapted its output using an OOK generation algorithm. In the receiver side, the incoming wake-up signal should be filtered to avoid noise, demodulated, amplified to increase its level, and decoded. The solution offers a maximum reachable distance of $15m$.

A different energy efficient addressing scheme has been presented in [70] and integrated on a low power wake-up radio [71]. The latter is based on [67] and includes both a receiver ($S\mu A$ -WuRx) with a current consumption of less than $1\mu A$ and a transmitter (WuTx), achieving a distance of more than $10m$. This scheme has been enhanced with a Time-Knocking (TicK) [70] addressing

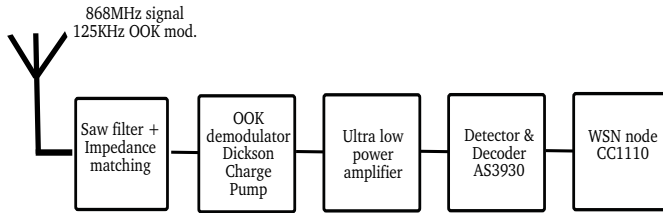

Figure 5: Wake-up receiver block of [69]

mechanism. The latter enables addresses encoding based on the wake-up times of the MCU. The transmitter sends a certain number of short WuCs at precise instants and uses time intervals separating the WuCs to encode the targeted address. These WuCs trigger the MCU to switch between LPM4 ($0.1\mu A$) and LPM3 ($0.5\mu A$). Based on the time interval between these WuCs, the receiver could decode the address. With this mechanism, non targeted nodes could early detect the address mismatch and stop the decoding even before receiving all the WuC, which is energy efficiency. Experimentation results have shown that Tick addressing based scheme outperforms MCU-decoding based [67], [72] mechanisms and correlation based mechanisms [73], [55] in term of current consumption. However this comes at the cost of a slightly long addressing period, which slightly increases and varies from $48ms$ to $68ms$.

To manage all these hardware solutions, a lot of MAC protocols have been designed in the literature. The next sections will be devoted to present these protocols.

IV. TAXONOMY OF MAC PROTOCOLS

Several WSN MAC protocols have been proposed in the literature. According to [74], [75], these protocols can be categorized into contention based protocols vs. reservation based protocols, and hybrid protocols. Contention based protocols are based on CSMA scheme. They may be further split down into synchronous vs. asynchronous protocols. In synchronous schemes [76], [77], nodes wake up periodically at the same time and communicate with each other in common active periods. Synchronization requirements may effect the network performances and increase energy consumption. This problem has been avoided using asynchronous MAC protocols, in which nodes decide when to wake up independently from one another. But this requires a coordination mechanism that allow neighboring nodes to meet the schedule of one another in. Two schemes of coordinations can be distinguished, i) a transmitter node starts by transmitting a preamble [45], or ii) it starts by transmitting a wake-up message [78] to indicate the start point of data transmission. The former is an example of MAC protocols using one radio, whereas the latter corresponds to MAC protocols using a wake-up radio. The use of a preamble necessitates that receivers periodically sample the channel to meet this preamble, while the use of

a wake-up radio eliminates this sampling. Nodes that detect the preamble during the sample period should wait until the reception of data and, then they go back to sleep. Whereas, the waiting time in the second scheme is limited to the time separating the wake-up message transfer and the data transmission, which is very short. MAC protocols using one radio suffer from long periods of idle listening (for channel sampling) and waiting time, which increases energy dissipation and results in high latency. This is completely avoided when using MAC protocols with wake-up radio.

Reservation based protocols can be divided into [74]: TDMA (e.g., PEDAMACS [79], TRAMA [80], DEMAC [48], LMAC [81], Arisha [82]), CDMA, and FDMA MAC schemes. Hybrid protocols combine reservation based and contention based schemes to reach high performances. IEEE 802.15.4 [46], ZMAC (Zebra MAC) [83], and Funneling MAC [84] are examples of this category. Existing state-of-the-art taxonomies are shown in fig. 6.

MAC protocols using wake-up radio have been emerged recently as an alternative to one radio based asynchronous MAC protocols. Since these protocols (one radio based MAC) are asynchronous and use only one radio, low duty cycle should be performed to protect the battery power and extend its lifetime. The value of the duty cycle, however, depends totally on the duration of the preamble transmission and could not be reduced indefinitely. When reducing the duty cycle, nodes spend most of the time in sleep mode which reduces receiver energy dissipation due to idle listening. However, longer preambles are required to avoid deafness, resulting in high energy consumption in the transmitter side. From this point of view, not only a trade-off between energy efficiency and latency is present when duty cycling the radio, but also another strong trade-off between energy consumption at the transmitter side and energy saving at the receiver side is remarked. This affects significantly the network performances and reduces its capacities.

Therefore, MAC protocols using wake-up radio are preferred nowadays, especially with the constant advances in circuitry and hardware technology. Using a separate wake-up radio, duty cycle is completely eliminated and so, all the presented drawbacks and trade-offs are avoided. Nodes spend all the time in sleep mode while the wake-up radio serves as a small eye that keeps watching and monitoring the channel. If a node wants to transmit a packet to its neighbor, it simply starts by sending a short wake-up message to it. As soon as the receiver's wake-up radio detects the wake-up signal, it immediately wakes up the main radio which will perform the required tasks and then go back to sleep until a next event happens, which reduces both energy consumption and latency. Therefore, we are focusing in this paper on this category of MAC protocols.

The main difference between wake-up MAC protocols and traditional asynchronous single-radio based MAC

Work	Frequency	Implement	Energy consumption	Wake-up time	Sensitivity	Out put power	Addressing support	Range	Bit rate	Characteri	PER
PicoRadio [53]	2 GHz	MEMS/CMOS	1.6mW (TX) / 380 μ W (Rx)	/	-75 dBm	/	Yes	20m	160kbps	Transmit & receive	/
Radio-triggered [58], [59]	433 MHz	simulation	passive	2.8 ms	/	51 dBm	No	About 3m	/	Receive	/
[67]	868,5Mhz	simulation	876nA @ 3V = 2628nW	/	/	27 dBm	Yes	7,5 m	/	Receive	10 %
[68]	868 MHz modulated to 125 kHz	PCB	2.78 μ A @3V	Wake-up signal send time = 13ms	-52 dBm	+10 dBm	Yes	40m	/	Receive	5 %
[43]	868 MHz modulated to 125 kHz	/	3.5 μ A	/	/	+20 dBm	Yes	90m	/	Receive	5 %
[71]	868 MHz	off-the-shelf	1 μ A	48ms-68ms	45 dbm	+27 dBm	Yes	10m	1 kbps	Transmit & receive	/
[69]	433MHz, 868MHz or 2.4GHz	CMOS	8.7 μ W	/	-53 dBm	10 dBm	Yes	15m	/	Receive	/
[60]	902MHz to 928MHz	PCB	Passive (battery free)	/	/	/	Yes	4,5m	/	Transmit & Receive	/
[61]	902MHz to 928MHz	PCB	Passive (battery free)	721ms @ 1.5 m	/	/	Yes	5m	/	Receive	/
[63]	915M Hz	PCB	Passive (battery free)	443ms @ 1.5 m	/	/	Yes	5 m	/	Receive	/
[63]	915M Hz	PCB	1A	235ms @ 1.5 m	/	/	Yes	11m	/	Receive	/
[36]	/	Off-the-shelf	Passive	2,528 ms	/	/	Yes	/	/	Receive	/
[64]	300 MHz	/	2.8 μ W	/	-65 dBm	/	Yes	8 m	/	Receive	/
[65]	916MHz	/	20 μ W	/	-69 dBm	+30 dBm	/	200m	/	Receive	/
[66]	2.4GHz	CMOS	20 μ W	/	-50 dBm	/	Yes	/	50 kbps	Receive	/
[55]	433MHz	CMOS	470nW 910nW (signal reception)	/	/	/	Yes	/	9600bit/s	Receive	/
[57]	902-928 MHz	CMOS	8.5 μ W	Latency is 8.1ms, turn-on time is 1.6s	-73 dBm	/	Yes	/	1kbps-200kbps	Receive	/

Table III: Wake-up radio hardware overview

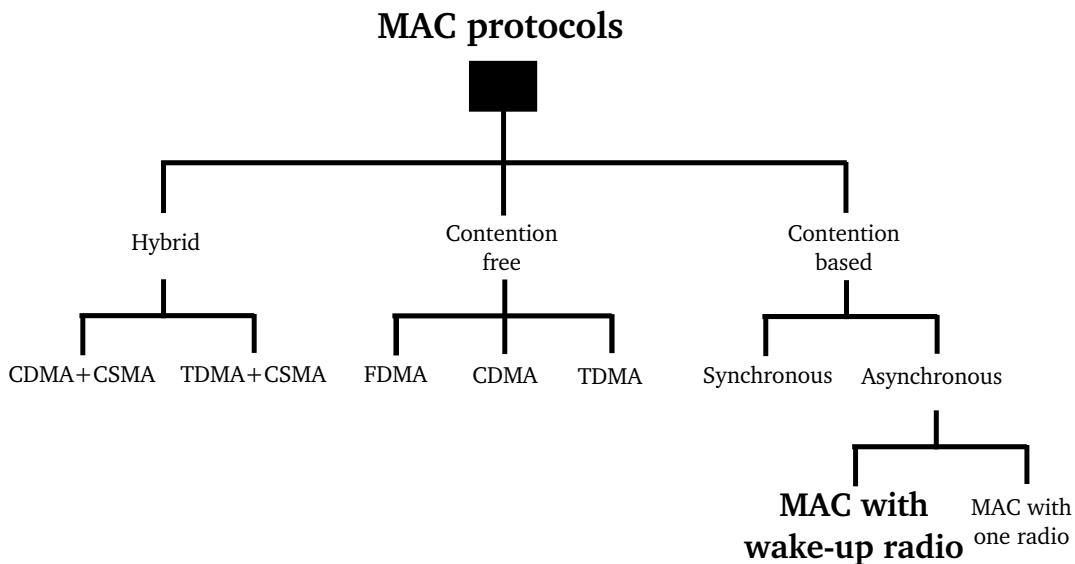

Figure 6: Existing classification of WSN MAC protocols

protocols is that single-radio based MAC protocols use only duty cycle to control the main radio, while wake-up MAC protocols manage it through the use of the wake-up radio. The latter may follow different strategies, and involve some techniques of duty cycling. Based on the strategy followed by the wake-up radio, we divide MAC protocols using wake-up radio into three main categories: i) duty cycled wake-up MAC protocols, ii) non-cycled wake-up MAC protocols, and iii) path reservation wake-up MAC protocols. From the first category, two subclasses are distinguished: static wake-up MAC protocols and traffic adaptive wake-up MAC protocols, while the second category is again divided into two other classes: always-on vs. radio-triggered wake-up MAC protocols. The latter can be again split into two subclasses: passive vs. ultra low power active wake-up MAC protocols. Path reservation wake-up protocols may be organized in two subclasses, broadcast based wake-up vs. addressing based wake-up. The proposed classification is presented in fig. 7.

V. DUTY CYCLED WAKE-UP MAC PROTOCOLS

In this class of MAC protocols, the wake-up radio is generally chosen to have identical power characteristics as the main radio, in order to avoid problems due to the possible difference between the transmission ranges of the two radios. Most protocols use a radio capable of receiving as well as transmitting wake-up messages, while few other protocols employ a very low power wake-up receiver that is able to only receive a wake-up message. All the protocols of this category share a common feature of duty-cycling the wake-up radio. Based on the duty cycle's policy, two subclasses can be distinguished, static vs. traffic adaptive. Note that duty cycled wake-up MAC protocols are different from traditional duty cycle aware MAC protocols. In the latter, the duty cycle is

performed by the main radio, while the wake-up radio is duty-cycled in the former.

A. Static Wake-up MAC Protocols

In static MAC protocols, the wake-up radio uses the same cycle during all the network's lifetime and does not follow the dynamic changes of the network. Adopting a steady duty cycle may facilitate the MAC protocol implementation and utilization due to its simplicity. However, this makes it inflexible and slows its responsiveness, which rises the end-to-end delay.

STEM [78] is an example of a canonical multi-hop protocol in this category. Separate channels are used for the wake-up radio and the main radio, which prevents interference between data and wake-up messages. Depending on the wake-up message form, two variants are derived from this scheme, i) STEM-B and, ii) STEM-T [85]. In STEM-B, when an initiator node wants to communicate with a target node, it starts transmitting beacon packets carrying the MAC addresses¹ of both the transmitter and the receiver until a beacon packet meets an active period of the targeted radio and receives an acknowledgment from it. Then both the transmitter and the receiver power on their main radios to start data communication, while keeping the wake-up radios duty-cycling periodically to check the presence of wake-up messages, as illustrated in Fig. 8. If a collision occurs on the wake-up channel, nodes detecting it wake up their main radios without sending back any acknowledgment. As the initiator will not receive the ACK from the target node, it starts transmitting data in the next cycle. After a defined time, nodes that do not receive any packet on

¹This is represented in Figures. 8, 9, 10, 11, 12, 13, 14 by the symbol @ which indicates that the WB includes the receiver's address

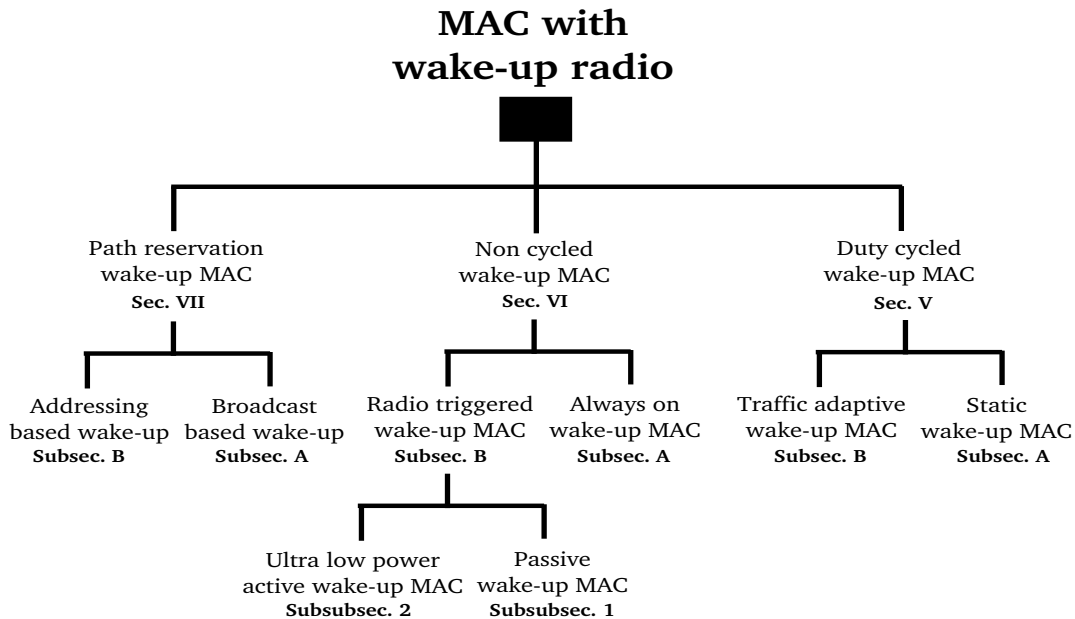

Figure 7: Mac protocols with wake-up radio : new taxonomy

the data plane return to the monitoring state while only targeted nodes keep their main radios on during data transfer. STEM-T has been driven as a simpler variant in collision handling, which simplifies the wake-up policy. Instead of sending a wake-up beacon with addresses, in STEM-T the wake-up message is a simple tone, but the same procedure is followed for data transmission when a collision happens. Its simplicity comes at the cost of waking up all the neighboring nodes, which increases power consumption. Further, the wake-up acknowledgment is eliminated, and this conducts the initiator to send the wake-up tone for a sufficient amount of time. The latter may be higher than that used for sending a wake-up beacon, which increases the latency. The two variants of STEM allow to save energy only in scenarios where the network is in monitoring state most of the time (more than 50%). To improve its capacities, it has been combined with GAF, a topology control protocol, where it has shown high energy saving and reduced its consumption to 1%, but for increased latency. Given the asynchronous nature of the wake-up radio, the target node should listen to the medium for a duration not less than, twice the transmit time of a beacon packet, plus the inter-beacon spacing.

LPR [33] is a hybrid scheme that combines scheduled rendezvous with RFID-based addressed low power wake-up. Each node is equipped with a low power RFID radio that follows duty cycle. In this scheme, inter-nodes data communication should pass through the base-station in a single-hop star topology, which is responsible for forwarding it to the target node, and thus a node wake up time (duty cycle) is scheduled with the base-station. At the time of the rendezvous, the base-station broadcasts a pre-wake-up announcement to all the awoken

nodes, preventing them from accessing the channel to avoid potential collision. It then sends out an addressed wake-up for the target node, followed by data packets transmission. In case the base-station does not enqueue any packet, the addressed node uses the information provided by the wake-up signal to re-synchronize its clock with that of the base-station to correct drift. If in the scheduled wake-up time the node has packets to transmit to the base-station, it switches its main radio and starts the data transfer right after the wake-up signal. When they finish, the nodes go back to sleep, scheduling another rendezvous at T_{lpr} (lpr stands for low power rendez-vous) times from the current one.

DCMAC [38] is another static duty-cycled MAC protocol. It is based on periodic listening/sleeping mechanism combined with synchronization for the goal of saving energy in multi-hop based networks. This is because in the targeted hardware, the wake-up radio has the same capabilities as the main one. When there is data to be delivered, the node performs listening by activating its two radios. When the channels are found free, the nodes sends a busy tone. The awoken nodes activate their main radios and a neighbor will be selected according to several metrics. This selection is done in three phases. In the first one, the nodes decide the forwarder area by transmitting the location information of the transmitter and the sink in an RTS packet. Only nodes which are within the data forwarding area continue to the next phase, the others switch off their radios. In the second phase, nodes that are candidates calculate the cost function based on the location information, the link quality of the channel, and the remaining energy of the candidate. In the last phase, the priority of the node is calculated and the node with the highest priority will be

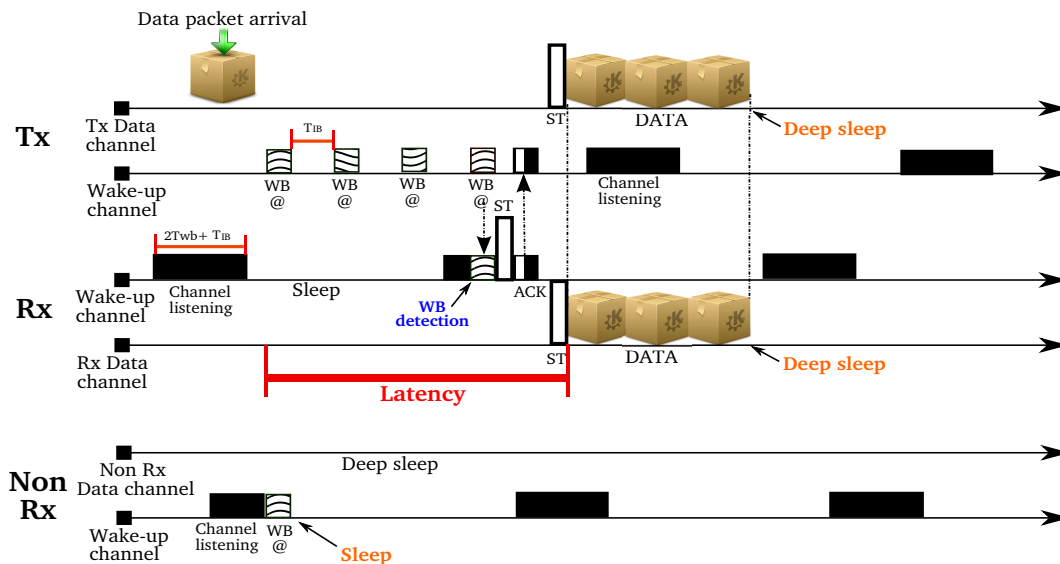

Figure 8: Example of a static wake-up MAC: STEM-B

selected to respond with a CTS. The procedure will be repeated at each hop until the data packet reaches the sink. DCMAC tries to save energy and reduce latency through choosing the best next hop. However, it has high computation complexity that is energy consuming.

OPWUM is a similar scheme that has been presented in [39] but with a simpler and more efficient fashion. When a sender node that has not any information about its next hop neighbor, wants to transmit data, it should start by sending an RTS packet to wake up all its neighborhood. Each awoken node by this RTS sets a BE before responding by a CTS, depending on a given metric value. The metric is chosen according to the application and it can be the remaining energy for example. Thus the larger the remaining energy is, the shorter the BE would be. In other words, the node that has the biggest budget of energy will be the first that respond to the RTS. After having received the CTS, the sender transmits an About To Send (ATS) to inform all the neighboring nodes about the selected node to be the next receiver.

Multi-Radio MAC (MR-MAC) protocol [86] combines the use of a p-persistent preamble sampling MAC approach with a dual-radio scheme for multi-hop networks. The CC2420 radio transceiver has been chosen for data communication, and the CC1000 as a wake-up radio. The former operates in the $2.4GHz$ high frequency band because of its large bandwidth, while the wake-up radio operates in the $433MHz$ low frequency band as it is used to only control the channel. When there is data to transmit, the wake-up radio starts transmitting Micro-Frame Preambles (MFP) [87] carrying the address of the receiver and the time of the next data transmission. For more energy conservation, the neighborhood sleep schedule based preamble [88] is coupled with the preamble strobing mechanism [40], where each node keeps in a table the wake-up schedule of all its neighbors. Based

on this information, it sends a wake-up beacon just before the wake-up time of the targeted node. After each wake-up beacon, the sender waits for an ACK to stop transmitting wake-up beacons and start data transfer. Piggybacking data into the preamble frame (when the data packet is small) [89] has also been introduced in MR-MAC, allowing to keep the main radio in sleep mode all the time for more energy saving. The authors drive some equations to find the optimum duty cycle that leads to the minimum energy consumption, and the optimum transmit power of the two radios that allows to cover the same area with less energy dissipation. Using a slow data rate radio operating in a low frequency band for preamble exchange may achieve good energy efficiency, as it performs low power operations. However, the energy consumed by the preamble sampling mechanism is still not negligible, mainly when the sender is not aware of the receiver's wake-up schedule. MR-MAC also results in a high latency, as the sender waits until the receiver wakes up to start data transmission.

DCW-MAC [21] is another multi-hop scheme that duty cycles the wake-up radio statically. It is based on the idea of combining ultra low power wake-up receiver with optimal duty cycling. The wake-up radio used in this protocol is only able to receive a wake-up beacon, while all the other tasks are delegated to the main radio. The latter is responsible for transmitting wake-up beacons when there is data packets to be communicated. Since the sender and the receiver are not synchronized, and the wake-up receiver follows a duty cycle scheme, the sender should transmit a precise number of wake-up beacons, to guarantee meeting the receiver. After each wake-up beacon, the sender turns on its main radio to check whether there is an acknowledgment destined to it. The acknowledgment (BACK) is sent by the main radio of the receiver, when its wake-up radio detects the

wake-up beacon. After acknowledgment reception, both of the sender and the receiver start data communication using their main radios. An acknowledgment (DACK) should be transmitted after data reception. Since the main radio is responsible for transmitting the wake-up message, frequent transitions between transmitting mode and receiving mode (waiting for an Ack) result in some energy dissipation.

A comparison summarizing all the cited static duty-cycled MAC protocols is presented in Tab. IV

B. Traffic Adaptive Wake-up MAC Protocols

In traffic adaptive MAC protocols, the nodes' wake-up time is variable and changes dynamically to satisfy the network traffic load. Nodes try to fix the next rendezvous for data communication based on the actual data rate. This makes the protocol flexible but does not eliminate the delay due to synchronization problems.

Rate Estimation MAC (RATE-EST) [34] is a traffic adaptive multi-hop wake-up MAC protocol that tries to predict dynamically the next wake-up time based on the packet arrival rate. Similar to STEM, it trades energy for latency. However, a mechanism has been introduced to control and delimit the delay, and to diminish the energy consumption resulted from awaking all the neighborhood for each data packet. Instead of immediate transmission of packets, a transmission queue is used. When the number of packets in the queue reaches a certain threshold, the node's wake-up radio starts transmitting simple tones. These wake up all the sender's neighboring nodes (full wake-up), which should activate their main radios to receive a filter packet that indicates the intended receiver that should remain active during the data transfer. At this moment, the non targeted nodes may go to deep sleep to conserve energy. As this is considered costly in terms of energy dissipation, a triggered wake-up has been introduced by the authors (see fig. 9). An initiator node tries to schedule this wake-up with a receiver T seconds after its previous data transmission, based on traffic load estimation. The sender will inject this value on each data packet sent. In case of no data packet is communicated within $T_{thresh}sec$, from the time of the triggered wake-up, the nodes should go back to sleep and wake up after $T - T_{thresh}$. The authors, according to the traffic state, tried to find dynamically the optimal value of T that minimizes the energy consumption, avoiding as well as possible pricey full wake-ups.

In [90], an improved version has been proposed where the authors studied and adapted RATE-EST MAC to support the multi-hop environment with multiple flows. In this case, each node plays the role of a sender and a receiver which should share its queue between several destinations and adopt various wake-up schedules from different senders, and thus it has to adapt different T values (triggered wake-up) consequently. RATE-EST saves energy and amortizes the energy cost of communi-

cation over multiple packets by buffering them, and by using triggered wake-up scheduling. However, the latter raises the problem of synchronization at the receiver side. Furthermore, buffering data packets is not suitable for delay sensitive WSN applications, since it introduces delay that increases latency. To better enhance RATE-EST protocol, a mechanism based on using multiple, non-interfering wake-up channels has been introduced in [35], to reduce the increased contention of the multi-hop environment with multiple flows, and to diminish the impact of full wake-ups that will only affect a subset of the sender's neighbors.

A different traffic adaptive wake-up MAC protocol for WSNs has been introduced in [91], where the authors address the traffic load change issue and its impact on radio transition time and power. As the transition from deep sleep to active mode requires both time and energy, the use of a wake-up radio in high data rate should be motivated by a gain that justifies the transition cost. The authors propose a hybrid mode where on demand MAC based on a wake-up radio is used for low data rate scenarios, while a sleep scheduled MAC is used as soon as the traffic load increases beyond certain threshold. If the threshold is not exceeded by all the nodes at the same time, a short information should be carried by the wake-up message indicating the operation mode of the next communication. Both modes follow a CSMA/CA scheme; in dual radio mode the wake-up radio uses CSMA/CA to send wake-up messages, while in single radio mode, CSMA/CA is used by the main radio to transmit data packet. When the dual radio mode is running, the sender starts by sending, over the wake-up radio, a wake-up message similar to an RTS packet, containing the address of the receiver to avoid waking up all the sender's neighbors. The receiver accordingly responds by a CTS packet, and switches on its main radio to start data communication, which should be acknowledged later using the wake-up radio. Switching between dual radio mode and single radio mode according to traffic load has shown high energy efficiency. However, it is not specified whether the wake-up radio is always-on, or it follows a duty cycle scheme. Note that the same issue has been investigated in an earlier work by Jurdak et al. in [92] and [93].

A comparison summarizing all traffic adaptive duty-cycled MAC protocols is presented in Tab. V

C. Advantages, Disadvantages, and Features

Duty cycled wake-up MAC protocols share the feature of using a wake-up radio that has similar performances as the main radio. This allows a large wake-up range at the same scale as that of data communication, and a more elaborated communication. It, however, comes at the cost of a higher energy consumption. To make the addition of a wake-up radio effective, the latter should consume less energy than the main one. This is to

Protocols	Wake-up message nature	Wake-up message source	Energy dissipation factors	Energy conservation mechanisms	Latency reasons	Collision avoidance
STEM-B [78]	Addressed and acknowledged beacon	Wake-up radio	Transmitting several wake-up beacons to meet the receiver	Beacon strobing	Waiting the wake-up time of the receiver	/
STEM-T [85]	Simple tone	Wake-up radio	Unnecessary wake-up of all the neighborhood	Ack elimination	Longer wake-up tone	/
LPR [33]	Addressed	Wake-up radio	Synchronization	/	Inter-node data communication should pass through the sink	pre-wake-up announcement
DCMAC [38]	Busy tone with CTS from the best next hop	Wake-up radio	Unnecessary neighborhood wake-up, Listening with two radios, Next hop determination overhead	Best next hop selection	waiting the best next hop determination	CCA before transmission
MR-MAC [86]	Addressed MFP	Wake-up radio	Neighborhood sleep schedule maintaining	Preamble strobing, Data piggybacking	Waiting the next hop wake-up time	/
DCW-MAC [21]	Addressed beacon with BACK	Main radio	Switching between Tx and Rx	Beacon strobing	Waiting the receiver wake-up time	/
OPWUM [39]	RTS packet	wake-up radio	Calculation overhead	Receiver selection	/	BE

Table IV: Comparison between static duty-cycled wake-up MAC protocols

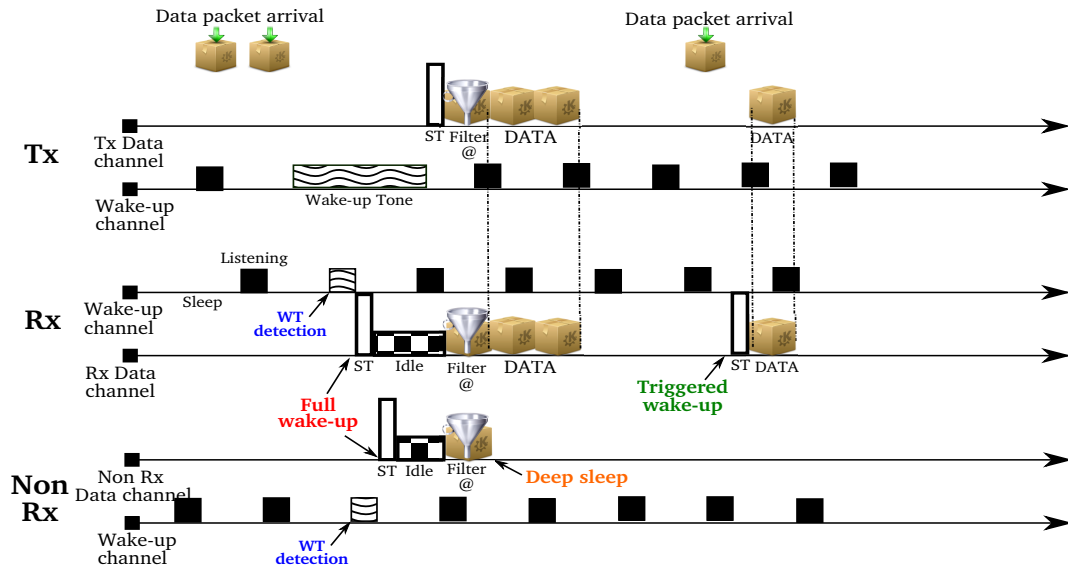

Figure 9: Example of a traffic adaptive wake-up MAC: RATE EST

Protocols	Wake-up message nature	Wake-up message source	Energy dissipation factors	Energy conservation mechanisms	Latency reasons	Collision avoidance
RAT-EST [34]	Simple tones	Wake-up radio	Unnecessary neighborhood wake-up, Synchronization	Next rendezvous estimation, Data buffering	Queue utilization	/
RAT-EST [90]	Simple tone	Wake-up radio	Unnecessary neighborhood wake-up, Synchronization	Next rendezvous estimation, Data buffering	Queue utilization	/
RAT-EST [35]	Simple tone	Wake-up radio	Synchronization	Next rendezvous estimation, Data buffering	Queue utilization	Multiple wake-up channels
[91]	RTS	Wake-up radio	Switching overhead	Alternating between dual radio and single radio modes	waiting for nodes to change their modes	RTS/CTS

Table V: Comparison between traffic adaptive duty-cycled wake-up MAC protocols

make duty-cycling the wake-up radio instead of the main one for more energy saving. Although this permits the node to avoid deafness, duty cycle is considered as a strong reason for latency. In static wake-up MAC, nodes duty cycle the wake-up radio constantly, regardless of the channel traffic conditions, while they duty cycle it dynamically in traffic adaptive wake-up MAC protocols. The implementation of the static-wake up category is simpler than the latter. This simplicity comes at the cost of rigidity, which does not exist in traffic adaptive wake-up MAC protocols that are more responsive to channel changes. Tab.VI summarizes advantages, disadvantage and features of duty cycled wake-up MAC protocols.

VI. NON-CYCLED WAKE-UP MAC PROTOCOLS

Protocols belonging to this category aim at overcoming the drawback of duty cycling the wake-up radio. According to the technique used, two schemes can be distinguished: i) the use of a low power wake-up radio that is active all the time, ii) the use of a passive circuit that should be powered from the wake-up signal. For both cases, latency is highly reduced as the wake-up message will be received immediately. However, the energy consumed depends on the wake-up component used. The main drawback of this class of MAC protocols is the possible difference between the wake-up and data ranges.

A. Always-on Wake-up MAC Protocols

MAC protocols of this class are based on an always-on low power wake-up radio that is able of transmitting and receiving wake-up messages. Although the wake-up

radio is low power, leaving it active all the time conduct to a non-negligible power consumption.

PicoRadio [11], [94] can be considered as the first wake-up radio MAC protocol destined for WSN. It is a multichannel wake-up MAC protocol that combines CDMA with CSMA. In PicoRadio scheme, every node is assigned a unique data channel using the CDMA scheme, in addition to a common control channel used for channel assignment and wake-up messages exchange. To be assigned a channel, each node monitors the common control channel (CCC) for a random period of time to be aware of its neighbors' channels. It then selects randomly an unused channel and announces it with its neighbors' selections in a channel assignment packet (CAP) using CSMA scheme. To avoid choosing an overlapping channel, nodes keep their neighbors' selected channels in a channel assignment table (CAT). If a node detects a conflict, it switches to another unused channel. When a node wants to transmit a packet to its neighbor in a multi-hop path, it first wakes it up by transmitting a wake-up beacon on its wake-up radio (Fig. 10). The wake-up beacon carries the address of the receiver, which is its channel number. When the receiver's wake-up radio detects the wake-up message, it triggers the main radio. The sender also powers on its data radio and starts data communication that can be performed on a sender based or a receiver based mode. In the first mode, the receiver should switches its data radio to the channel of the sender that uses its own channel to transmit packets. In the second one, the receiver uses its own channel and the sender follows it. To avoid collision, the first solution has been used, however the receiver based technique was found more practical and suitable to the PicoRadio scheme, since after the wake-up period,

Subclasses	Static duty-cycled [78], [85], [33], [38], [86], [21], [39]	Traffic adaptive duty cycled [34], [90], [35], [91], [92], [93]
Features	Wake-up radio has the same performances as the main one	
	Wake-up radio duty cycles statically	Wake-up radio duty cycles dynamically
Advantages	Wake-up range similar to data communication range, Sophisticated communication (no false alarm)	
	Simple to implement	Flexible to traffic conditions changes
Disadvantages	Possible latency due to duty-cycling	
	Suffer from rigidity	Complicated implementation

Table VI: Advantages, disadvantages and features of duty cycled wake-up MAC

receiver's data radio is active and ready to receive data from the sender that knows the target's channel address. After successful data transmission, the receiver should send back an ACK to the sender. If the latter did not receive the ACK after a predefined time, retransmission is required. Using multichannel CDMA scheme permits to avoid collisions and thus to achieve energy saving, and reduce latency in the same time. Yet, collisions at the wake-up plane are not avoided (no CCA). CDMA is also known by its high complexity and suffers from energy hungry calculations due to performing channel assignment periodically, which is considered as an NP complete problem.

LPW [33] is based on a low power active RFID radio in a one-hop communication scheme, where nodes communicate with each other through the base-station. The protocol adopts a mechanism, in which the base-station is used to prevent potential collision between nodes. In fact, when it has packets to be transmitted to a certain node, it begins by transmitting a pre-wake-up announcement to all the nodes, preventing them from accessing the channel. After that, an addressed wake-up message should be transmitted to the target node followed by data packets transfer. The addressed node will detect the wake-up signal and thus switches on its main radio to perform data communication. It returns back to the RFID state once the transfer finishes. When a node has packets to be transmitted to the base-station, a channel scan should be performed to avoid collision. This scan is achieved using both the RFID wake-up radio and the data radio, as the former alone is not able to differentiate between a wake-up signal and a data packet transmission. If the signal is a pre-wake-up announcement detected by the RFID radio, then the node should wait until the wake-up and the data transfer

finish before accessing the channel. Otherwise, the signal is recognized by the main radio as a data packet, and so it can start data communication once the channel becomes free. However, the use of the main radio to sense the channel is energy consuming. Moreover, following one hop communication scheme limits the scope and applicability of the protocol.

CMAC [20], [95] is another CDMA multichannel multi-hop MAC protocol of this category. In this protocol, the wake up radio has not its own wake-up channel, but it is tuned to a node's default channel. When there is a packet to be transmitted, the sender's wake-up radio switches to the receiver's channel and monitors it for a period of time to avoid collision. If the channel is found busy, the sender should wait until the channel becomes available. Otherwise, a REQ wake-up message containing the sender's identifier (channel number) will be transmitted by the sender's wake-up radio in the target's channel, after a random back-off time. In this case, the receiver replies with a CON (confirm message) after a short duration of time. The CON contains the sender channel number to announce the winner (if more than one sender is trying to access the same receiver). In case the receiver detects a wake-up signal on its wake-up radio while it is receiving a data packet on its main radio, a WAIT message should be transmitted to the sender indicating the time at which it will finish its ongoing communication. The WAIT message may also indicate which node will be the first to transmit (in case of multiple senders). After successful channel negotiation, the receiver switches its main radio to the sender's channel and the sender power on its main radio to start data transmission. An ACK should be sent by the receiver using its own channel (the sender should switch to the target's channel), after completing data

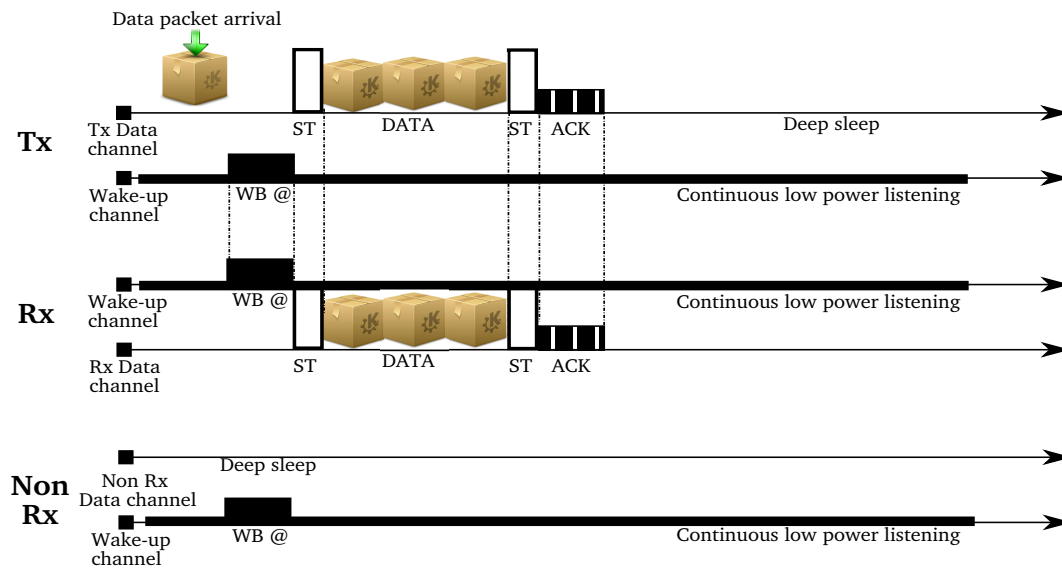

Figure 10: Example of an always-on wake-up MAC : PicoRadio

transmission. The use of a different channel for ACK exchange allows to avoid potential collision that could happen at the data plane. Using the same channel that is shared between the main radio and the wake-up radio has many drawbacks. First, it may leave the wake-up radio unaware of a wake-up message coming from another sender when it switches to the target's channel waking the appropriate node up. This results in a non-negligible latency when waiting for the target node. In addition, periodically switching between sender's and receiver's channel can significantly affect energy and the transmission delay.

LESOP, a cross layer protocol [25] designed for target tracking in dense multi-hop based wireless sensor networks is an example of real application in WSN. In this scheme, each node is equipped with an additional wake-up radio that is able to send or detect busy tones. A node that first detects the target is considered as a leader, and it broadcasts a busy tone through its wake-up radio to wake up all its neighbors to sense the environment. The detection information performed by the neighboring nodes will be then sent and merged at a new leader. The latter will receive the track information that includes a profile of the target, from the first leader, and takes its role (of the first leader), repeating the same procedure until the target disappears in the surveillance region. All the inter-node communications are done by packets to exchange relevant data through the main radio, and by busy tones for waking up each others using the wake-up radio.

Another MAC protocol has been proposed for critical infrastructure monitoring applications (LECIM) [96]. It is based on beacon-enabled framed slotted Aloha MAC protocol combined with a low power wake-up radio [55]. In LECIM applications, a coordinator node plays the role of the access point and communicates with end nodes

in a one hop communication link, forming a large star topology. Before starting data transfer, the coordinator node wakes up the intended node(s) by sending a wake-up beacon carrying slots and synchronization information. When receiving this beacon, the end-node starts transmitting its data after having chosen a random slot in the frame, and then goes back to sleep. Using a low power wake-up radio destined to WBAN in this kind of application is not suitable, since WBANs are deployed in a very short geographic area. A multi-hop version of this work has been presented in [97], where the authors consider a network composed of a LECIM coordinator and clusters. Each cluster comprises cluster head acting as a parent with several cluster head as children. Each child cluster head supervises a group of endpoints. Only cluster heads are dotted with a wake-up radio to rapidly exchange data, which enables low energy operations.

Authors in [98] propose AWD-MAC protocol for BANs. In order to reduce collision, this protocol is based on RICER scheme, in which the sensor nodes (senders) could not start data transmission until the coordinator (receiver) wakes them up (i.e communication occurs in a star topology). To achieve this, two steps are needed. In the first one, the receiver performs neighbor discovery, where it broadcasts a beacon using its main radio to all the neighborhood. When this packet is received by the wake-up radio, the node switch on its main radio, chooses a random slot and sends its data packet containing its address and data rate. The coordinator responds thus by an ACK to confirm this node discovery, saving its information in a table. After having finished the first phase, the nodes pass to the second one, where asynchronous communications can be performed. The coordinator in this phase is able to wake up a precise node exactly when the latter is available, since it is aware of its data rate.

A comparison summarizing always-on MAC protocols is presented in Tab. VII

B. Radio-Triggered Wake-up MAC Protocols

The wake-up radio is only able to receive the wake-up message. It can be either a semi-passive circuit with a very low power consumption, or a completely passive one that uses the power from the wake-up signal. The node's lifetime can thus be extended to several years using sleep mode, while offering instantaneous responsiveness.

1) *Passive Wake-up MAC Protocols*: Passive solutions are described in this section, where the wake-up circuit in this class does not need a battery. Instead, it harvests energy from the incoming wake-up signal and uses it to wake up the node. The possible drawback with this category of MAC protocols is the latency due to time needed to collect energy from the wake-up signal, in addition to the reduced wake-up range due to the limited amount of energy used.

A MAC protocol for ultra-wideband (UWB) multi-hop based sensor networks has been proposed in [99]. The authors target the problem of using UWB radio technology in WSNs that promises low power consumption with very high data rates, but this is at the cost of high acquisition time, and thus increased overhead. An auxiliary RF-based wake-up radio has been integrated in the node in conjunction with the UWB based radio, for the purpose of achieving fast way of channel control signaling. The proposed wake-up radio is a passive circuit [59], coupled with dynamic channel allocation [94] to avoid collision problems at the wake-up plane. The designed scheme achieves lower latency with a significant improved throughput.

In [100], the RFIDimpulse scheme [36] has been integrated with the IEEE 802.15.4 non-beacon enabled mode standard, and it has been applied for a multi-hop network topology as a wake-up MAC protocol. To diminish the cost of integrating both an RFID reader and tag in each node, the IEEE 802.15.4 radio can act as a reader and in the same time, as the main radio. All 802.15.4 MAC functionalities are reused, including the CCA and the collision avoidance binary exponential back-off mechanism. It however eliminates the periodic radio's duty cycle as RFIDimpulse remotely and on-demand wakes up the intended receiver. When there is a packet to transmit, the sender's radio transmits a wake-up signal then competes to access the channel following the contention access scheme. It so chooses a random byte slot and performs CCA. If the channel is found free then it starts transmitting. Otherwise, it switches to idle mode and attempt on a later time to access the channel by increasing the BE (backoff) and choosing a new random slot. When the receiver's tag is triggered, it turns on the MCU, which in turn activates the main radio to receive data. The latter will perform channel listening during the first 7 slots as in IEEE 802.15.4. If no

data packet has been received, it keeps active during an additional 15 slots. If within three attempts, the awakened node could not receive any packet, it should go back to deep sleep. Although RFIDimpulse achieves high energy saving by putting both the MCU and the main radio in deep sleep, it however presents some drawbacks. In fact waking up the intended receiver and then attempting to access the channel results in high energy waste, due to leaving the target in unnecessary listening mode when it could not reserve the channel for the first time.

RTM [101] is another multi-hop wake-up MAC protocol that is based on a passive wake-up circuit [59]. The wake-up circuit operates on the same channel of that for data communication. The wake-up follows the CSMA/CA scheme in the sense of sensing the carrier before transmitting to avoid potential collisions. If the channel is found free, a simple wake-up preamble will be transmitted. The latter does not carry any useful information, it is however, used to only energize the receiver's wake-up circuit. When a wake-up signal at a given radio frequency range is detected, the wake-up radio triggers the data radio through the interruption of the micro-controller. The sender then transmits a CTS packet, indicating the desired targeted node. Upon reception of this packet, the required node responds by an RTS packet and stays awoken, while all the others go back to sleep. Data transmission can take place just after receiving the RTS packet. An ACK should be transmitted at the end of data communication. Combining wake-up radio features with IEEE 802.11 RTS/CTS is interesting, but the circuit used in the prototype [59] has some limitation, e.g., its wake-up range is about $3m$ only. More sophisticated circuits have been developed later on. Moreover, using a shared channel for both wake-up messages and data transfer may lead to collisions between data and wake-up messages. It also has an impact on the latency as only one transmission could take place at a certain time, and thus data transmission blocks wake-up signaling, and vis-versa. Furthermore, transmitting a wake-up preamble to wake up all the neighbor nodes and then exchanging RTS/CTS packets to select the appropriate receiver causes a waste in energy for the nodes awaked uselessly.

VLPM protocol has been proposed for star topology based wireless body area networks (BAN) [102]. The scheme is based on a wake-up transmitter [67] and a wake-up receiver [59], which are integrated in both the Ban Network Controller (BNC) and Ban Nodes (BNs) nodes, beside the main radio. The authors assume that wake-up messages carry the address of the intended receiver, which allows the non-targeted nodes to return back to sleep mode, just after decoding the address by the MCU, without powering on the data radio. Generally, the BNC sends a Res-WuP message to wake-up a specific node, and inform it of its allocated resource (as well as of other information). The BN responds then by

Protocols	Wake-up message nature	Wake-up message source	Energy dissipation factors	Energy conservation mechanisms	Latency reasons	Collision avoidance
PicoRadio [11], [94]	Addressed beacon	Wake-up radio	Channel assignment overhead	/	/	Multiple data channel
LPW [33]	Addressed message	Main radio	The use of both wake-up and data radios to perform channel scan	/	Data communication through the base-station	Pre-wake-up announcement, CCA
CMAC [20], [95]	Adressed and confirmed message	Wake-up radio	Frequent switching between sender's and receiver's channel	/	A same channel is shared between data and wake-up radios, Switching to the target channel	Multichannel, CCA, BE
[96]	Adressed and acknowledged beacon	Wake-up radio	Synchronization	/	Data exchange through the sink	/
[98] AWD-MAC	Addressed message	Wake-up radio	Discovery overhead	Organized transmissions using data rate table	/	RICER based

Table VII: Comparison between always-on wake-up MAC protocols

data packets, followed by an Imm-Ack from the BNC. In case of emergency, the BN sends a WuP message to the BNC. The latter replies by a Res-Ack which allows the BN node to start data communication, after which an Imm-Ack will be sent by the BNC.

Another MAC protocol based on the same wake-up radio [59] has been proposed for BANs in [103], [104]. Since BANs are characterized by the presence of emergency situations, a wake-up radio has been integrated to reduce communication latency. The protocol considers scenarios where BAN nodes (BN) communicate with the BAN network controller (BNC) in a star topology, and heterogeneous traffic with varied data rates both at BNs and the BNC. In periodic traffic, the BNC initiates the communication by waking up BNs according to a specific schedule. In case of emergency traffic, such as notification of a sudden increase or decrease of the heart rate, BNs should report this information quickly to the BNC. This is considered as random traffic that requires low latency. Given the two types of traffic, two wake-up schemes have been adopted. For normal traffic, a TDMA-based wake-up scheduling has been designed. In this scheme, the BNC maintains in a table a wake-up schedule for each node according to its traffic intensity, which allows BNs to remain in sleep mode all the time without any duty cycle until a wake-up signal from the BNC is detected. Following a simple superframe structure that is composed of a beacon period and a

contention free period (CFP) containing 15 Guaranteed Time Slots (GTS), the BNC uses a very low power wake-up signal to interrupt the wake-up radio of the BN. If the latter has no data packet to transmit, it then replies by an NACK (negative ACK), otherwise by an ACK announcing that it is awoken. In this case, a beacon containing synchronization and slot information will be sent by the BNC to the BN. Data communication can thus start in the GTS slot and ends up by an ACK from the BNC. In case of random traffic (emergent communication), the BN wakes up by itself and sends a wake-up signal to the BNC. The latter responds by an ACK followed by a beacon for resource allocation. Data transfer from the BN can take place, followed by an ACK. In addition to idle listening elimination, collision and retransmission overhead are also avoided by adopting a TDMA approach in conjunction with the wake-up radio. However, synchronization overhead effect is not considerable, which is justified by the fact that BANs have small network size. PSMAC [105] is another example of a protocol that combines CSMA/CA with TDMA using a wake-up receiver.

The WUR-TICER [106] is based on combining the wake-up radio mechanism with the energy harvesting concept. Adopting the energy harvesting technique is considered as a more reliable alternative that provides a theoretical infinite lifetime. Another enhancement of the scheme is the use of a nano-watt wake-up radio receiver

[107], which allows the main radio to be active only for reception and to spend all the other time in sleep mode. Each energy harvesting (EH) node in the network extracts energy from the energy harvested device and distributes it using an energy flow controller. The latter is responsible for handling the harvested energy and recharged a super capacitor when the harvested energy exceeds the required one. Furthermore, a power manager (PM) [108] is integrated to make the balance between the harvested and the consumed energy. In WUR-TICER, communications are based on extending the TICER MAC protocol [27] with a wake-up radio. It is carried in a single hop topology, where the base-station node (BS) collects data from other end device nodes (ED). When the end device has a packet to transmit to the BS, it broadcasts a wake-up beacon containing its address, which reserve the channel. Upon receiving the wake-up message, the receiver turns on its main radio and transmits an ACK. At the same time, the transmitter switches to receive mode to get the ACK. Once it is successfully received, the sender performs CCA, and then transmits the data packet. Associating the energy harvesting technique with the wake-up radio mechanism is an energy efficient. However, when the energy harvested and the energy stored in the super capacitor is not sufficient to operate, the node should wait until the required threshold will be reached, which may results in a non-negligible latency.

DoRa [109] is another passive protocol that is based on energy harvesting mechanism in one hop networks. Initially, all the nodes are in the sleep mode. When the base-station wants to recover data from a given node, it wakes it up by sending a wake-up signal containing its address. The targeted node replies by a data packet. This scheme allows to completely avoid collisions, since at a given time only one node could access to the channel.

A comparison summarizing passive wake-up MAC protocols is presented in Tab. VIII

2) *Ultra Low-Power Active Wake-up MAC Protocols:* To cope with the short wake-up range problem, some ultra low power components can be added to the wake-up circuit. Although these components use some energy from the battery, their consumption remains negligible compared to that of the main radio. MAC protocols in this scheme are neither always-on protocols (which are highly power consuming), nor duty-cycled protocols (which have high latency). They in contrast, combine ultra low energy consumption with high responsiveness.

RTWAC [67] uses an additional wake-up circuit that is attached externally to the mote, which allows the main radio to be completely switched off while communication is not required (fig. 11). When a sender wants to transmit a packet to a receiver in a multi-hop scheme, it switches on its data radio and then performs a clear channel assessment (CCA) before sending the wake-up signal. This is to avoid collision. The wake-

up signal is modulated to allow sending the receiver's address with some simple command messages. Upon detecting a wake-up message at $868.5MHz$, the wake-up radio extracts power from the signal and uses it to interrupt the micro controller that is in the low-power mode (LPM4). When the latter wakes up, it interprets the wake-up message and check weather it is destined to it based on the address transmitted with the message. In case the receiver is the targeted node, it executes the command message contained in the wake-up signal, for example, waking up the main radio. Otherwise, it switches back to the sleep mode to save energy. RTWAC MAC protocol balances the energy and latency by reducing the power consumption of a node when there is no need to communicate, and immediately waking it up when required.

ZeroMAC [110] follows the same process of 802.11 DCF [111] with the use of an additional wake-up radio called RF watchdog. The latter achieves the same sensitivity as the main radio and offers frequency channel selectivity with only a few amount of energy ($230\mu W$). When it detects a signal higher than the predefined threshold, the wake-up radio triggers the processor as an indication of an ongoing communication. The latter generates an interrupt to the main radio that activates it to start data reception. A wake-up signal should be transmitted before each RTS/CTS message. When there is a packet to transmit in a multi-hop scheme, the sender broadcasts a short signal that wakes up all the neighboring nodes within its hop. Since the RF watchdog is designed to be low power, it could only detect the presence of a wake-up signal without interpreting it. Therefore, the sender should wait for a short period of time to guarantee all its neighbors have activated their main radios, and then it transmits an RTS packet indicating the intended receiver. At this time, all the non-intended neighboring nodes go back to sleep mode, and the targeted node should respond by a wake-up signal to wake up all its one-hop neighbors followed by a CTS packet to indicate the sender. This allows non-targeted nodes to go back to sleep mode. Right after, data transfer can take place and an acknowledgment should be transmitted at the end. The designed RF watchdog can be considered as an ultra low power wake-up receiver, since only simple and low power components has been employed. However the solution suffers from costly overhearing due to large overheads of waking up all the neighboring nodes for each hop, in addition to RTS/CTS packets transmission. This leads to high energy dissipation of all the networking nodes. Note that no details has been provided about the wake-up range.

Another MAC protocol using an ultra-low-power wake-up receiver has been introduced in [112]. The wake-up receiver is based on the commercial *AS3932* chip [113]. It can be triggered by a $125KHz$ wake-up signal modulated on an $868MHz$ HF carrier. It consumes only

Protocols	Wake-up message nature	Wake-up message source	Energy dissipation factors	Energy conservation mechanisms	Latency reasons	Collision avoidance
[99]	Addressed and acknowledged message	Wake-up radio	Channel allocation overhead	/	Switching between request and reply channels	Dynamic channel allocation, multiple access based on time hopping codes, RTS/CTS, CCA
[100]	Addressed message	Main radio	Unnecessary waiting due to wake-up transmission before reserving the channel	/	/	CCA and BE
RTM [101]	Simple preamble	Main radio	Waking up all the neighborhood	/	Use of the same channel for data and wake-up	CSMA/CA, RTS/CTS
VLPM [102]	Adressed beacon	Wake-up radio	/	piggybacking resource allocation on controle messages	/	Slot allocation, A special radio frequency for the uplink wake-up message
[103], [104]	Adressed and acknowledged beacon	Wake-up radio	/	TDMA scheme	/	Wake-up schedule table
WUR-TICER [106]	Adressed and acknowledged beacon	Wake-up radio	/	Use of energy harvesting mechanism	Data exchange through the sink, Waiting to harvest a sufficient amount of energy	CCA
DoRa [109]	Adressed message	Wake-up radio	/	Use of energy harvesting mechanism,	/	Each node has a dedicated slot to transmit

Table VIII: Comparison between passive wake-up MAC protocols

$6\mu W$ of power and its wake-up range is more than $8m$. In this scheme, data communication is based on network clustering, in which sensor nodes report their monitoring information to a specific repeater, considered as a cluster-head, which in turn communicates it to the base-station. Before to start data exchange, the repeater broadcasts a default wake-up signal to all the neighboring nodes, followed by a binding request to ask them the creation of a cluster. Each node that has received the request should reply by a confirmation containing its ID to the repeater, after a calculated back off time. The repeater then responds by an ACK for each node that has confirmed the request, indicating that it belongs to the actual cluster with the repeater as a parent and sensor nodes as children. To exchange data,

the source node should transmit a wake-up message addressed to the destination node. The latter broadcasts a CTS message and then switches to receive mode and keeps waiting for data that should be acknowledged at the end. All the communication packets should be preceded by CCA to avoid collision.

Similarly to [104], another wake-up MAC protocol based on a two stage wake-up receiver and a TDMA scheme has been proposed in [114]. The protocol is destined for bats tracking and monitoring. Authors faced a lot of challenges due to the light weight of these animals, i.e., about $20g$, which does not allow them to carry a sensor node of up to $2g$. A strongly limited power budget is thus considered, which affects and limits both communication and computation capabilities. Therefore,

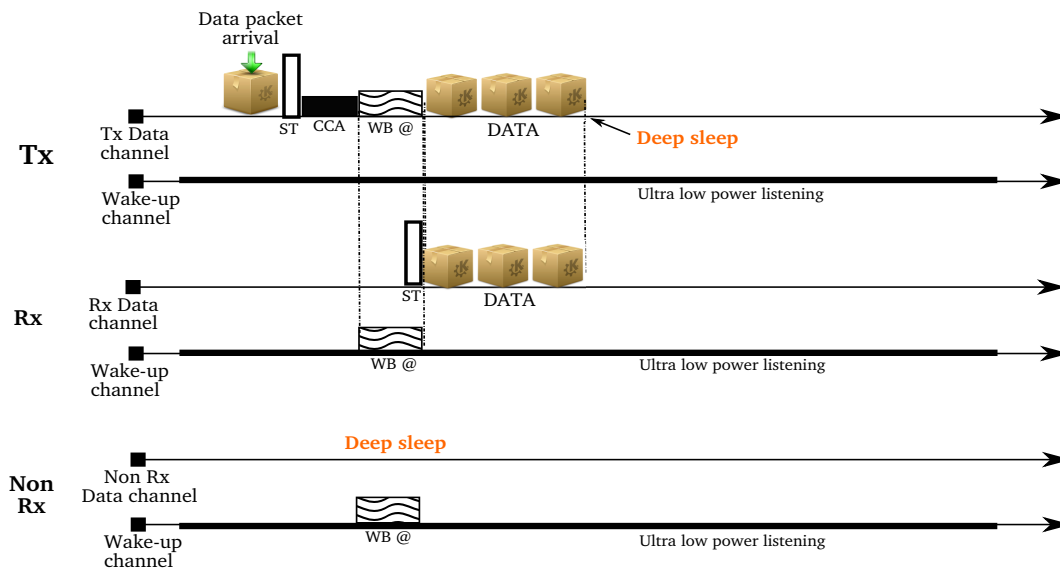

Figure 11: Example of a radio-triggered wake-up MAC : RTWAC

a duty cycle based wake-up receiver similar to [57] has been followed. The authors focus on downlink communication (from mobile nodes to ground stations) to localize the flying bats. Since these are energy-constrained, localization has been combined with communication in two carrier signals, which are the $868MHz$ and the $2.4GHz$ frequency bands. When a mobile node enters the ground node's communication range, the latter sends to it a wake-up signal. When awakened, the mobile node waits for its slot (determined by the ground node based on a TDMA schedule). It then starts transmitting ranging signals in the $868MHz$ and $2.4GHz$ frequency bands. It is possible that the ground node replies by a control signal, and then the mobile node should switch from transmit to receive mode for data reception.

A comparison summarizing ultra low power active wake-up MAC protocols is presented in Tab. IX

C. Advantages, Disadvantages and Features

Contrary to duty cycled wake-up class, in non-cycled wake-up class the main and the wake-up radios are different in term of performances. Two approaches for managing the wake-up radio can be distinguished. i) The wake-up radio is put on all the time, or ii) it is triggered only when there is a wake-up signal addressed to it. In the latter, the wake-up radio may be passive (it is powered by the wake-up signal), or low power active (it uses low energy at the order of few micro Watts from the battery). An advantage that is shared between all non-cycled protocols is the high responsiveness with the complete elimination of latency due to waiting time for the receiver cycle, as nodes are ready to receive all the time. Moreover, high energy conservation is targeted in radio-triggered schemes, notably in passive wake-up MAC protocols. These protocols use the energy from the

electromagnetic waves of the wake-up signal. This does not exclude low power active wake-up MAC protocols, which utilise the battery to help the wake-up signal power. The reason behind is to extend the wake-up range in order to allow efficient communication, since in fully passive wake-up the energy collected from the signal is weak to cover a large range. Different from them, always-on scheme allows the wake-up signal to reach high distance. However, the latter is less energy efficient comparatively to radio-triggered schemes. All the discussed features are summarized in Tab.X.

VII. PATH RESERVATION WAKE-UP MAC PROTOCOLS

Data communication and channel reservation can be performed in parallel, as on the one hand, communications in WSN are generally in multi-hop links, and on the other hand the wake-up procedure is independent to data transmission and uses a separate radios channels. In this class of MAC protocols, a node reserves the next channel (i.e the next hop) while it is receiving data from the previous node. Consequently, a packet can be forwarded to the next hop node as soon as it is received, which eliminates the setup delay. According to the wake-up policy, either all the nodes of the next hop will be awakened, or only the concerned one. Two sub-classes can hence be distinguished: Broadcast based wake-up, vs. addressing based wake-up.

A. Broadcast Based Wake-up MAC Protocols

As it has been already explained, in broadcast based wake-up, the current receiver makes path reservation by waking up all the next hop nodes. After that, a filter packet will be transmitted to indicate the required node, allowing all the unintended others to go back to sleep.

Protocols	Wake-up message nature	Wake-up message source	Energy dissipation factors	Energy conservation mechanisms	Latency reasons	Collision avoidance
RTWAC [67]	Addressed message	Wake-up radio	/	/	Waiting to harvest a sufficient amount of energy	CCA
ZeroMAC [110]	Broadcasted signal	Main radio	Unnecessary neighborhood wake-up	/	/	CCA, RTS/CTS
[112]	Addressed message	Main radio	Cluster establishing overhead	/	/	CCA, BE, RTS/CTS
[114]	Adressed beacon	Wake-up radio		Slot waiting		

Table IX: Comparison between ultra low-power active wake-up MAC protocols

Subclasses	Always-on wake-up [11], [94], [33], [20], [95], [25], [96], [97], [98]	Passive wake-up [99], [100], [101], [102], [103], [104], [105], [106], [109]	Ultra low power active wake-up [67], [110], [112], [114]
Features	Wake-up and main radios haven't the same performances		
	Wake-up radio is put on all the time	Wake-up radio is put off all the time	Wake-up radio uses few W from the battery
Advantages	Wake-up radio is ready all the time, no latency		
	Simple to implement	Wake-up radio uses only wake-up signal power, high energy conservation	Good energy conservation
Disadvantages	Wake-up range is slightly shorter than that of data communication		
	More energy consumption	Short wake-up range	Hard implementation

Table X: Advantages, disadvantages and features of non-cycled wake-up MAC

Although it's simple to implement, a possible drawback with this scheme is the additional energy consumption due to waking up all the next hop neighboring.

PTW [115] is based on a duty cycled wake-up radio that is capable of sending simple tones. The idea behind PTW scheme is to perform data transmission and wake-up signaling in parallel (refer to fig. 12), so that the wake-up delay can be eliminated and thus the end-to-end latency will be reduced. When a node A wants to transmit data packet to node D , in multi-hop, through nodes B and C , it starts by sending wake-up tones on the wake-up channel during a predefined period that

should be long enough to be detected by the receiver B . At the end of the wake-up duration, all node A 's first hop neighbors (including B) should be awakened waiting for data reception. At this moment, node A transmits a notification packet (filter packet) on its data channel indicating that data packet is intended for node B only, which allows the other neighbors (like the not intended node on the figure) to go back to sleep. Following the reception of the notification packet, node B should respond the transmitter A by an acknowledgment on the data channel. In the same time, node B starts waking up its next hop neighbors and receiving data packet from A .

This procedure will be repeated until the packet reaches its destination D . Based on the assumption that the data transmission duration is superior than the wake-up period (the predefined duration of sending wake-up tones), for each hop except the first one, the wake-up delay overlaps with the packet transmission duration, and so it is eliminated from the end-to-end delay. If collision occurs and notification packets could not be received by the awakened node, this latter should stay active up to a timeout duration.

Making the wake-up signaling in parallel with data reception can significantly reduce the delay. However, in addition to the high energy dissipation resulted from waking up all the neighboring nodes each time (due to the use of simple tones), making the wake-up duration fixed may effect both energy and latency. In fact, if the receiver wakes up early (at the beginning of the wake-up period), it could not answer the transmitter until the end of the wake-up period, which will increase energy dissipation and latency due to unnecessary waiting time. Moreover, this scheme can be applied only when the packet transmission is larger than the period of time separating two consecutive active periods of the control channel.

B. Addressing Based Wake-up MAC Protocols

As an improvement of broadcast based wake-up, in addressing based wake-up, the actual receiver wakes up only the intended next hop node which results in considerable energy saving.

LEEM protocol [116] aims to avoid continuous wake-up signals. To achieve this, each node's wake-up period is synchronized with its next hop neighbor, so that when a node A wants to transmit a packet to node B , it sends to it the wake-up message exactly in its wake-up period (as presented in fig. 13), which avoids wake-up channel occupation and reduces energy due to sending streams of wake-up messages for each hop. Similarly to PTW, LEEM protocol achieves actual data transmission and wake-up signaling of the next hop concurrently in a multi hop scheme. However, a sender node is able to wake up only the desired receiver, saving thus unnecessary wake-up's energy and reducing notification packet transmission delay. In addition, one or more channels could be reserved a-priori according to data packet transfer duration. When this latter is higher than the duty cycle period, the reservation is made one hop ahead (see fig. 13). Otherwise, it is made on N -hop ahead (fig. 14). In one hop ahead reservation scheme, the source node waits the wake-up period of its next neighbor and sends to it a REQ packet, containing its address and including an additional field that specifies the time duration of the current data transmission, estimated from the data packet size. If the data channel is currently free, the receiver replies back with a P-ACK packet (Positive ACK) and data transmission takes place after having

switching their main radios. Otherwise, the ACK will be negative (N-ACK). While a node located at the next hops (from the first one, in the figure, or further) is receiving data packet, it reserves the next hop's wake-up channel by sending a RES packet during its neighbor's wake-up period. This packet also has an additional field that specifies the instant time at which it requires the channel. If the receiver find that the channel will be free at that time, it replies with the P-ACK packet, and data transmission can start exactly at that time. When the data transmission duration is less than the duty cycle period, the reservation is done for N -hops (refer to fig. 14), as that of one hop fails to eliminate the delay. As soon as the node is awoken by its previous neighbor, it wakes up immediately its next neighbor (as wake-up periods are synchronized), following the same policy of REQ and RES messages exchange of that of one hop ahead reservation.

Reserving the channel for N hops may significantly reduce the end-to-end delay, notably when N includes all the intermediate nodes. However, collision can occur at any intermediate node. This not only increases energy dissipation at that node due to collision detection and packet retransmission, but moreover, it affects all the following reserved channels and makes them unused during all the reserved time. Furthermore, synchronizing nodes every hour is a hard task that consumes a lot of energy in large and dense networks. In addition, the complicated nature of the scheme, due to several complex calculations makes it more energy consuming.

An example of local monitoring application for security purpose is presented in [26], where a new wake-up radio based MAC protocol (SLAM) has been proposed. In local monitoring, sensor nodes exchange data packets and guard nodes oversee the traffic to determine malicious nodes. Using traditional mechanisms, guard nodes should remain active all the time to guarantee high level of security. SLAM has been designed to reduce the time a node should keep active to monitor the traffic. Therefore nodes are equipped with an additional wake-up radio allowing guard nodes to stay in sleep mode whenever no event happens and to immediately switch to monitoring state when required. To achieve this, before exchanging data packets over a multi hop scheme, nodes should wake up the guard node responsible of monitoring on the next hop to follow and supervise data communication. Therefore, in addition to check whether data packets has been dropped, delayed, modified, misrouted, or forged along the path from source to destination, SLAM adds another task to the guard node, in which the previous guard node should verify weather sensor nodes exchanging data have waken up the requisite guard of the next hop or fails due to malicious motivations. Experimentation results have shown that using a wake-up radio, a comparable level of security could be reached while listening energy savings of 30-129 times is obtained. Enhancements of

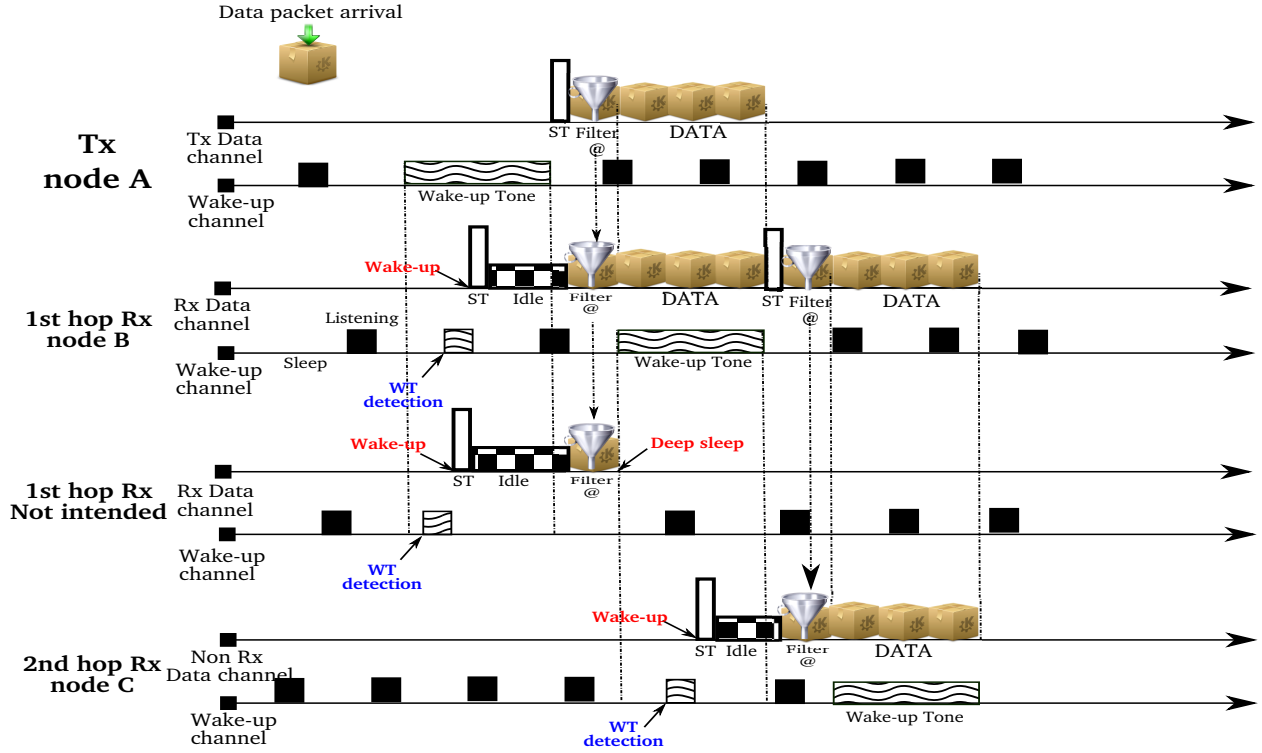

Figure 12: Example of a path reservation wake-up MAC : PTW

this work with more details have been presented in OD-ELMO MAC protocol [117], where two variants have been developed: i) Master On-Demand ELMO (M-ELMO) and ii) Simple On-Demand ELMO (S-ELMO). The difference between the two schemes resides in the wake-up mechanism followed by the node to wake up the guards of the next hop. The former adopts a complicated wake-up mechanism in which only the necessary nodes are awakened, while the latter makes use of a simple tone based wake-up to simplify the wake-up hardware. However, this causes the activation of all the neighboring nodes and thus leads to more energy consumption.

MELM [37] is another path reservation protocol that uses an approach similar to one hop ahead reservation of LEEM [116]. In addition, it is enhanced with a distributed collision avoidance mechanism. In this scheme, each node maintains a 2-hop scheduling table for the goal of controlling and deciding the time data transmission could take place. It allows also the elimination of the hidden terminal and the exposed terminal problems. When node A has data to transmit to node B, it sends a REQ packet asking for a new channel reservation. The receiver responds with a REQ-ACK packet that includes the possible free slot number based on its scheduling table. Data transmission can start once the sender and the transmitter agree upon a precise time slot. All nodes within a two-hop distance should update their scheduling tables according to the actual data transmission, which will help to avoid the problem of hidden and exposed terminals. Simulation results indicate that MELM out-

perform STEM and LEEM protocols in terms of energy efficiency and end-to-end delay. However, updating the scheduling table at each data transmission has a high overhead, which impacts on the energy consumption.

The authors in [118] enhance the STEM protocol [78] by proposing to use the pipelining mechanism. Thus, instead of waiting for the next hop listening time to wake it up after receiving the packet from the previous node, the intermediate node responds the RTS by an acknowledgement including the address of the next hop. The latter will be awakened by this ACK and thus will be ready to receive the data packet just after it finishes its reception at the intermediate node (without additional waiting time). By comparing the new version of STEM with the original one (without path reservation), a considerable improvement in term of end-to-end delay has been shown.

A different scheme, called CTP-WUR, has been presented in [119] where the authors enhance the Collection Tree Protocol (CTP) for data gathering by integrating the use of a wake-up radio. The idea behind CTP-WUR is to avoid sending the data packet to each hop in the network. However, when node A wants to transmit a packet to node C through node B, it will use the latter as a wake-up relay only, i.e node A wakes up node B just to ask it to wake up node C. Node A will then send data to node C directly without forwarding it through node B. This permits node B to completely avoid powering its main radio, which enables high energy saving and reduces the latency.

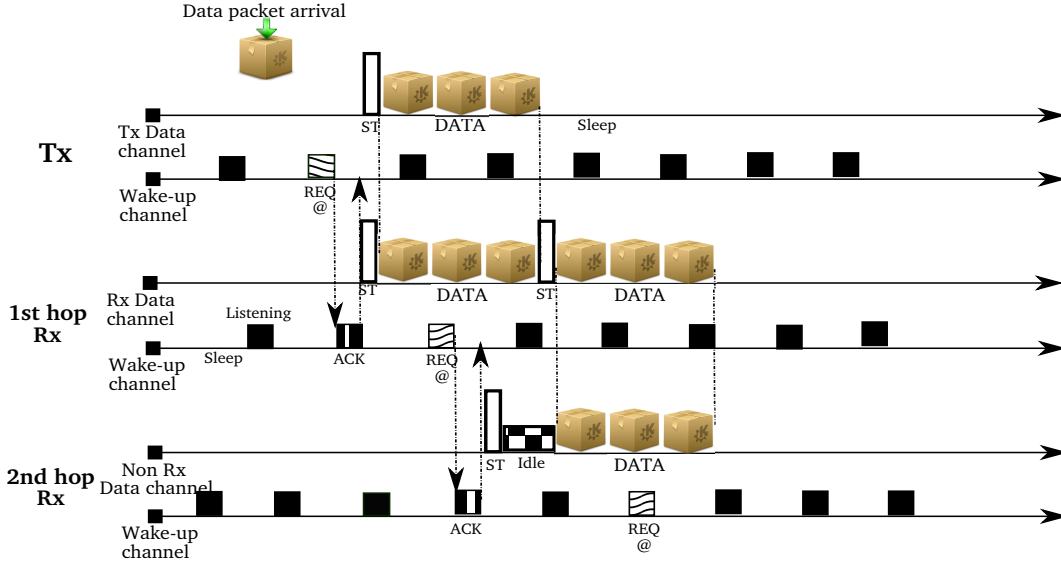

Figure 13: LEEM MAC protocol : One-HAR

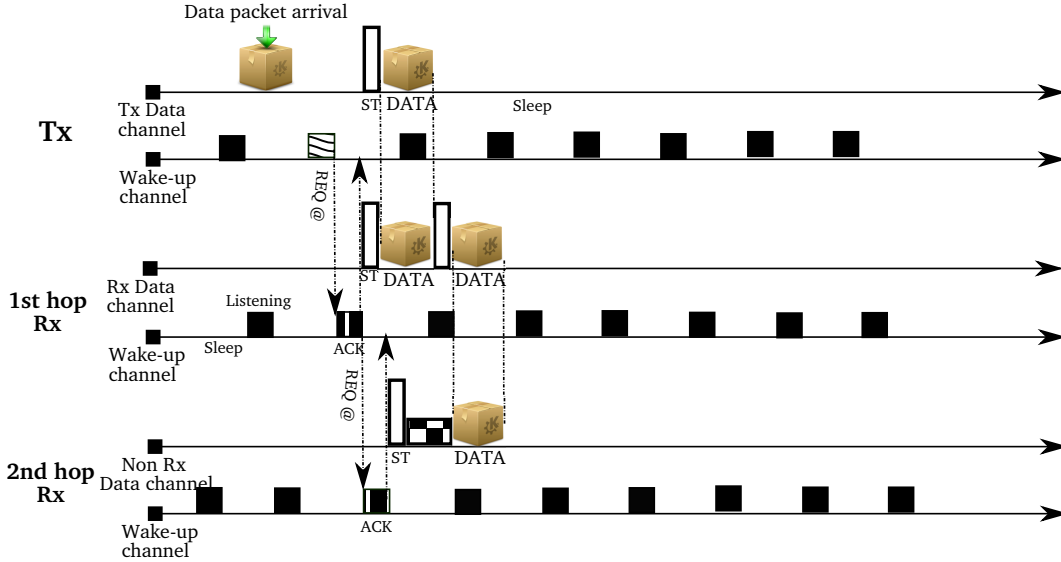

Figure 14: LEEM MAC protocol : N-HAR

A comparison summarizing all path reservation wake-up MAC protocols is given in Tab. XI

C. Advantages, Disadvantages and Features

In path reservation wake-up protocols, nodes take advantage from the additional (wake-up) radio to perform data reception and wake-up message transmission at the same time. This allows to reserve the next hop(s) and makes it ready to receive data packets, which eliminates all the path establishing waiting time. When reserving the path, the wake-up radio may transmit a simple tone which causes the wake-up of all the neighboring nodes (broadcast wake-up), or it indicates the address of the target node in the wake-up beacon (addressed wake-up). While the former is simple to implement, it

has high energy consumption due to the wake-up of all the neighboring nodes. This is completely avoided in addressed wake-up. Tab.XII summarizes this discussion.

VIII. ISSUES, CHALLENGES AND FUTURE RESEARCH DIRECTIONS

The simultaneous requirements in terms of energy preservation and that of high responsiveness have led to the design of several WSN medium access control protocols. Each of these protocols presents a different mechanism to handle the energy-latency tradeoff. The most recent and promising approach is to equip the sensor node with an additional low-power radio playing the role of an alarm that wakes up the main radio right after detecting a wake-up signal from a given node. This solution breaks the energy-latency tradeoff, since the high power

Protocols	Wake-up message nature	Wake-up message source	Energy dissipation factors	Energy conservation mechanisms	Latency reasons	Collision avoidance
PTW [115]	Simple tones	Wake-up radio	Unnecessary neighborhood wake-up	/	Wake-up channel occupation for a long time	/
LEEM [116]	Addressed message	Wake-up radio	Synchronization and calculations overhead	Wake-up message transmission at the receiver's wake-up time	/	/
MELM [37]	Addressed and acknowledged message	Wake-up radio	Scheduling table maintaining overhead		/	2-hop scheduling table
[118]	Acknowledged RTS	Wake-up radio	/	Use the same packet to acknowledge the previous sender and wake up the next receiver	/	RTS/CTS
CTP-WUR [119]	Addressed wake-up	Wake-up transmitter	/	Avoid sending data to the intermediate nodes	/	/

Table XI: Comparison between path reservation wake-up MAC protocols

Subclasses	Broadcast based wake-up MAC [115]	Addressing based wake-up MAC [116], [26], [37], [118], [117], [119]
Features	Data reception and wake-up message transmission happen in parallel	
	Wake-up message is a simple tone	Wake-up message carries the address of the intended node
Advantages	Next hop waiting time is eliminated	
	Simple to implement	Energy efficiency due to addressing wake-up
Disadvantages	Complicated implementation	
	More energy consumption	Complicated implementation

Table XII: Advantages, disadvantages and features of path reservation wake-up MAC

data radio is put in sleep mode all the time and wakes up only when it is required, which provides high energy saving and immediate data reception. This scheme not only removes unnecessary idle listening, but furthermore it reduces considerable collision and allows simultaneous wake-up messages transfer and data exchange due to the use of different channels. In other words, adopting a wake-up radio enables to solve many problems for delay sensitive and energy constrained applications. Demands of such applications are in constant progress, which requires new sophisticated MAC protocols that could respond to future needs notably in terms of sustainable energy supply through the reliance on environmental energy. Several MAC protocols using wake-up radios have been designed in this area. Some works have been devoted to compare these protocols of those using single radio (e.g., [31], [41], [42], [30], [47] and [120]). They show clear improvement with the use of the wake-up radio. The authors in [120] compared a real WuR hardware platform [68], [43] with four single radio based MAC protocols, IEEE 802.15.4 [46], B-MAC [45], X-MAC [40] and RI-MAC [121]. The driven scenarios correspond to real ongoing projects (Sant Vicenç dels Horts[122] and IB-ISEB project [123]). Simulation results showed not only high energy saving and reduced latency using the wake-up receiver, but also higher PDR and less complicated software implementations compared to single radio based schemes.

We remarked that all the protocols reported in this paper are evaluated only by simulation or theoretical analysis. Real implementation and testbed evaluation of wake-up MAC protocols represent a general perspective.

In this section, a summary of all the discussed categories of MAC protocols is presented. Representative MAC protocols of each class are chronologically reviewed in order to highlight the observed improvement. The possible issues and challenges according to both energy consumption and latency along with the achievable distance are given, and open research directions are discussed.

A. Always-on Wake-up MAC Protocols

Earlier solutions such as the PicoRadio scheme [11], [94], have focused on the use of an always-on low power radio. The purpose behind this scheme is the need to reduce energy consumption in monitoring applications while providing instantaneous data forwarding. It has been seen that in this kind of applications, more than 90% of energy is wasted while listening to the channel, as data communication takes place at a very short portions of time. The use of a low power radio with several orders of magnitude lower than the main radio may achieve high energy saving, but the energy consumption of this radio (that is always active) could not be neglected. Furthermore, its low energy budget may result in a reduced wake-up range comparatively to the high power

radio. This is still an open area where research is in progress.

B. Static Duty Cycled Wake-up MAC Protocols

To cope with the always-on protocols' problems, duty cycled wake-up MAC protocols have been introduced. They duty-cycle a wake-up radio similarly to the main radio in order to avoid the short range problem, but very low duty cycle is generally used. Static MAC protocols as STEM-B [78] use a fixed duty cycle ratio during all the network lifetime. This facilitates the implementation, but it does not allow adaptation to dynamic changes. Moreover, when performing duty cycle of the wake-up radio, the sender could not be aware of the receiver wake-up time. Wake-up messages are therefore transmitted until the reception of an ACK. This conducts to the fundamental problems of duty cycled protocols where high energy is dissipated due to unnecessary alternating the wake-up radio, and high latency due to the fact that the receiver is always dominating and the sender should wait until it becomes awoken to communicate data packets. Furthermore, if the wake-up messages are transmitted continuously (as in [115]), then the receiver cannot send back an early ACK, and the channel will be occupied during this period of wake-up messages transmissions, which prevent neighboring nodes from making another wake-up. The use of simple tones as a wake-up signal [85] causes even more energy dissipation, since all the neighboring nodes will be waked up.

C. Traffic Adaptive Duty Cycled Wake-up MAC Protocols

To compensate the problems of static wake-up MAC protocols, traffic adaptive MAC protocols have been introduced. RATE EST [34] tries to avoid the costly wake-ups caused by the submission of a simple tone and estimating the time of the next wake-up rendezvous based on actual traffic load. Using this scheme, each pair of sender and receiver sets a triggered future wake-up time to avoid waking up all the neighboring nodes. However, this needs time synchronization which is challenging in WSN due to the fast clock drifting.

D. Radio Triggered Non-Cycled Wake-up MAC protocols

To overcome problems related to duty cycled approaches, radio triggered wake-up MAC protocols have been designed. They are based on the idea of using either a passive or an ultra-low power active circuit that is always ready to detect the wake-up signal. First, a radio-triggered wake-up MAC protocol [99] used a passive scheme, based on a passive circuit [59] that does not need to be powered from the battery. Instead, it uses the wake-up signal to power itself and activate the sensor node by extracting the energy contained in it, which results in high energy saving. Further, this offers instantaneous

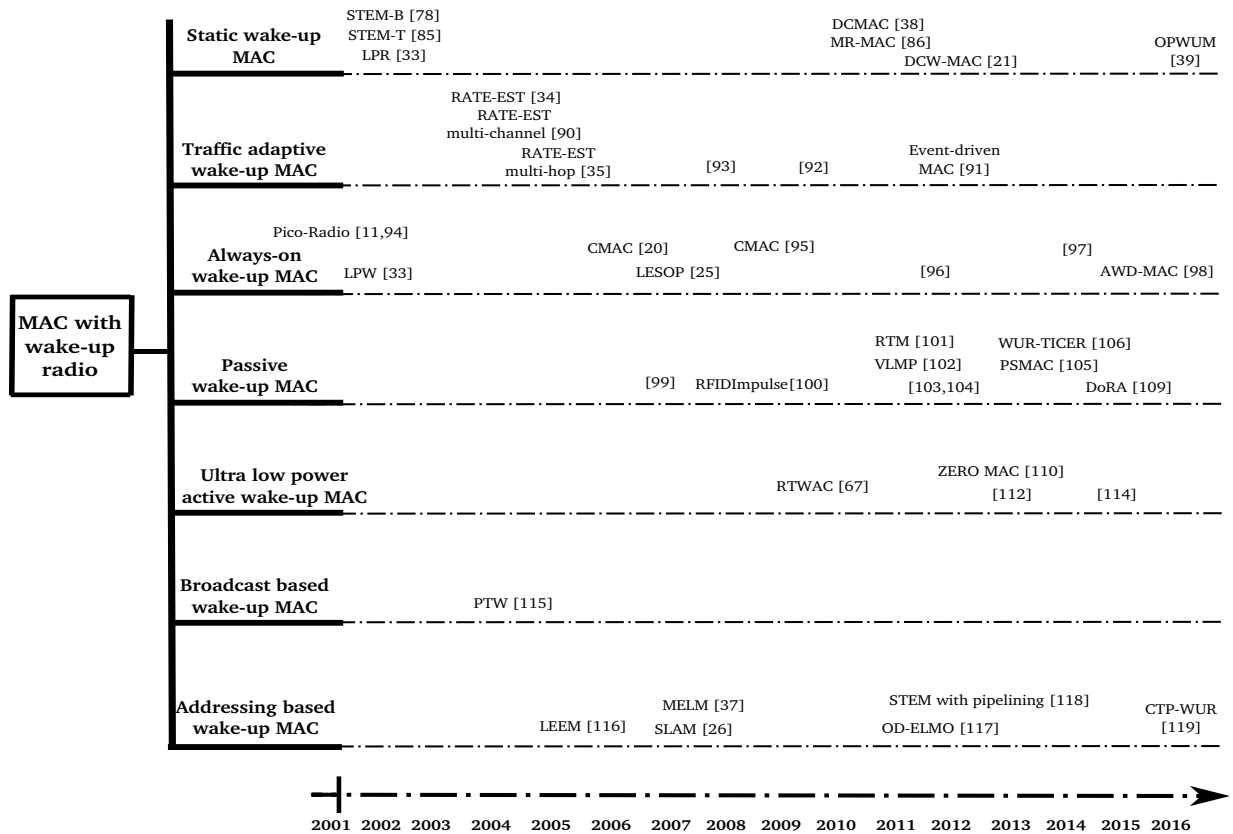

Figure 15: Wake-up MAC Protocols' Timeline

data reception and forwarding. The major drawback of this scheme is the limited wake-up range, which is at about $3m$ in [59]. An ultra-low power active circuit that increases the wake-up range to about $7.5m$ has been developed and proposed in [67]. However, this range is still insufficient and shorter than typical communication ranges. The circuitry technology progress may solve this problem. The works proposed in [68] and [43] present prototypes of circuits that may achieve up to $40m$ and $90m$, respectively, with ultra low power components that need only about $2.78\mu A$ and $3.5\mu A$, respectively. Another approach consists in completely eliminating the use of energy from the battery by incorporating an energy harvesting technique on the wake-up radio [106]. This is very efficient, but since environmental energy sources are not always available, it may add some delay to the wake-up procedure. Radio triggered wake-up MAC protocols (both passive and ultra low power active) are the most promising approaches for ultra low power high delay-sensitive applications. They present attractive features that have drawn most of the researchers attention, which is justified by the large number of wake-up MAC protocols that are based on radio-triggered concept compared to protocols of other categories (Fig. 15). However, an important issue which is still wide open is the triggering delay. The latter is considerably large with passive schemes. Ongoing research works are

attempting to reduce it, e.g., such as [124] and [125] which both achieve $8\mu s$.

E. Broadcast Based Path Reservation Wake-up MAC Protocols

Path reservation MAC protocols benefit from the dual channel availability by parallelizing data communication and wake-up signals exchange, which permits further minimization of the wake-up latency. However, the work presented in [115] is based on a simple wake-up radio that is capable of only transmitting busy tones. These causes the wake-up of all nodes within the sender's neighborhood, which is not energy efficient (for those nodes).

F. Addressing Based Path Reservation Wake-up MAC Protocols

Addressing based schemes have resolved the energy wasting problem of broadcast based schemes. However, the authors of [116] assume the use of a duty cycled wake-up radio. Consequently, the time gained from parallelizing data and wake-up transfer will almost be lost on waiting the next wake-up time of the receiver. An alternative approach is to combine radio triggered wake-up receiver with path reservation. This idea has been investigated in [26] and [117], but the wake-up circuit that has been used did not enable good performances.

Class	Protocols	Wake-up receiver used	Energy reduction mechanism	Latency improvement mechanism	Topology	Traffic load	Mobility support	Cross layer support	Coverage issue
Static duty cycle	STEM-T [85] STEM-B[78] LPR [33] MR-MAC[86] DCWMAC [21] LESOP [25]	Active	Duty cycling the wake-up radio	No	Multi-hop, one-hop	Low	Yes	Application	The same range
Traffic adaptive duty cycle	RATE-EST [34] RATE-EST with multihop [90] RATE-EST multi channel [35], [91]	Active	Duty cycling the wake-up radio, queueing packets, estimating the next rendezvous	Traffic load estimation	Multi-hop	Low and medium	No	No	The same range
Always-on	PicoRadio[11] [94] LPW[33] CMAC[20] [95] LESOP [25], [96]	Active	Using a low power wake-up radio	Putting the wake up radio active all the time, using multi-channel scheme	Multi-hop, one-hop	Low and medium	([25])	Routing ([95])	No problem with the coverage
Passive	[99] RFIDImpulse[36] RTM[101] VLPm[102] [103], [104] PSMAC[105] WUR-TICER[106] SLAM [26] OD-ELMO[117]	Passive	Avoid using the battery for the wake-up receiver and collecting energy from the signal	The wake-up receiver is always ready to be awoken	Multi-hop, one-hop	Low and medium	Mobility and dynamic changes ([26], [117])	Application ([26], [117])	Wake-up range is shorter than the data range
Ultra low power Active	RTWAC[67] ZERO-MAC[110], [112], [114]	Semi-passive with ultra low power consumption	Minimizing the battery use of the wake-up receiver	The wake-up receiver is always ready to be awoken	Multi-hop, one-hop	Low and medium	No	No	Wake-up range is slightly shorter than the data range
Path reservation	PTW [115] LEEM[116] SLAM [26] OD-ELMO[117]	Active or passive	Duty cycling the wake-up radio or powering it by the energy of the signal	Making data and wake-up transfer in parallel	Multi-hop	Events occur occasionally, events are periodic and aperiodic, and multiple events with various informations and varying packet sizes	[26], [117]	No	Wake-up range is slightly shorter or equal to the data range

Table XIII: Wake-up MAC protocols overview

Adopting a more efficient and up-to-date wake-up circuit may significantly improve it, such as [126] and [127], which is capable of decoding the received data to extract the sender address and transmitting wake-up and data packets with only few μW .

Finally, note that all works discussed herein use a traditional main radio that is capable of transmitting and receiving data in a-priori fixed/allocated channel. However, the use of a cognitive radio that is able of switching between different channels (when it is required) may be advantageous and represents an open research trend. A lot of works have been investigating the use of cognitive radio in this area [13], [128], [129]. But all these works are in the context of single radio based WSNs. Combining a cognitive radio with a wake-up radio may considerably enhance the system performances. It allows to minimize the energy consumption and the end-to-end delay by eliminating idle listening and overhearing, and reducing collisions. The cognitive radio offers a dynamic usage of the spectrum. This alleviates the collision issue in

dense WSNs, since opportunistic spectrum access is adopted. Moreover, it enables an overlaid deployment of multiple coexisting WSNs, which contributes to enhance the communication performances.

IX. CONCLUSION

We considered in this paper Asynchronous MAC protocols with wake-up radio, which present a promising solution to energy saving while assuring low communication delays in wireless sensor networks. A variety of MAC protocols of this category has been passed in review in this paper, with focus on canonical protocols. A proposed taxonomy based on energy consumption and latency issues has been given. State-of-the-art wake-up MAC protocols have been split into three categories: i) duty cycled wake-up MAC protocols, ii) non-cycled wake-up MAC protocols, and iii) path reservation wake-up MAC protocols. Two subclasses emerge from the first class, are static wake-up MAC protocols vs. traffic adaptive wake-up MAC protocols. Non-cycled wake-up

MAC protocols have been divided into two subclasses: i) always-on wake-up MAC protocol, and ii) radio-triggered wake-up MAC protocols. The last class can be again divided into two subclasses: ii) passive, and ii) ultra low power active wake-up MAC protocols. Path reservation wake-up MAC protocols are split into two subclasses: i) broadcast based wake-up vs. ii) addressing based wake-up MAC protocols. All these classes are summarized in Tab.XIII.

Through this study, we realize that asynchronous wake-up MAC protocols are in general better than all the other MAC protocols in terms of reducing energy consumption and latency. Wake-up MAC protocols that duty cycle the radio guarantee a larger wake-up range than non-cycled wake-up MAC protocols. The range for the former is similar to the communication range of the main radio, as identical radios are used, while non-cycled wake-up MAC protocols make use of low power active or even passive wake-up radios. However, duty cycling the wake-up radio leads to the drawback of traditional MAC protocols, i.e latency. Always-on wake-up MAC protocols may offer high responsiveness to network events, but at the cost of increasing the energy consumption. This could be managed using ultra low power wake-up MAC protocols that ensure timely responsiveness with high energy efficiency, by offering large and sufficient wake-up range. Path reservation wake-up technique allows for simultaneous data forwarding and wake-up messages transmission. We find it promising to use this technique along with some other wake-up radio techniques to design an effective asynchronous wake-up radio based MAC protocols.

Eliminating idle listening can be considered as a great step forward in WSNs, but the constant progress in circuitry and wireless technologies raises different issues that should be tackled. One of the most challenging issues is to improve the wake-up range while completely eliminating the use of the battery power (passive wake-up). Research is in progress in this area and some solutions have been proposed, such as the use of energy harvesting technologies that are making fast progress. However, reducing the time needed by a node to extract energy is still an open research trend. Another possible issue related to energy consumption is false wake-up signals. These signals cause the wake-up of non-intended nodes, which is considered as a source of high energy waste. They might be caused by either unfiltered packets from the wake-up transmitter, or the use of unsophisticated or faulty wake-up receivers. Dealing with this issues is also an open research direction.

ACKNOWLEDGEMENT

The authors are grateful to the journal editor in chief for handling the manuscript, and the anonymous referees for their comments and suggestions, that have considerably helped in improving this paper through the revision rounds.

REFERENCES

- [1] B. Rashid and M. H. Rehmani, "Applications of wireless sensor networks for urban areas: a survey," *Journal of Network and Computer Applications*, vol. 60, pp. 192–219, 2016.
- [2] M. H. Rehmani, *Cognitive Radio Sensor Networks: Applications, Architectures, and Challenges: Applications, Architectures, and Challenges*. IGI Global, 2014.
- [3] C. Gui and P. Mohapatra, "Power conservation and quality of surveillance in target tracking sensor networks," in *Proceedings of the 10th annual international conference on Mobile computing and networking*. ACM, 2004, pp. 129–143.
- [4] T. Bokareva, W. Hu, S. Kanhere, B. Ristic, N. Gordon, T. Bessell, M. Rutten, and S. Jha, "Wireless sensor networks for battlefield surveillance," in *Proceedings of the land warfare conference*, 2006, pp. 1–8.
- [5] C. R. Baker, K. Armijo, S. Belka, M. Benhabib, V. Bhargava, N. Burkhart, A. D. Minassians, G. Dervisoglu, L. Gutnik, M. B. Haick, *et al.*, "Wireless sensor networks for home health care," in *21st International Conference on Advanced Information Networking and Applications Workshops (AINAW'07)*, vol. 2, 2007, pp. 832–837.
- [6] G. Werner-Allen, K. Lorincz, M. Ruiz, O. Marcillo, J. Johnson, J. Lees, and M. Welsh, "Deploying a wireless sensor network on an active volcano," *IEEE Internet Computing*, vol. 10, no. 2, pp. 18–25, 2006.
- [7] P. Zhang, C. M. Sadler, S. A. Lyon, and M. Martonosi, "Hardware design experiences in zebrantet," in *Proceedings of the 2nd international conference on Embedded networked sensor systems*. ACM, 2004, pp. 227–238.
- [8] J. M. Rabaey, M. J. Ammer, J. L. da Silva, D. Patel, and S. Roundy, "Picoradio supports ad hoc ultra-low power wireless networking," *Computer*, vol. 33, no. 7, pp. 42–48, 2000.
- [9] V. Raghunathan, C. Schurgers, S. Park, and M. B. Srivastava, "Energy-aware wireless microsensor networks," *IEEE Signal Processing Magazine*, vol. 19, no. 2, pp. 40–50, 2002.
- [10] CC2420 Single-Chip 2.4 GHz RF Transceiver, pp. 13, Retrieved from Texas Instruments. URL: <http://focus.ti.com/lit/ds/symlink/cc2420.pdf>, Mar. 2010.
- [11] J. L. da Silva Jr, J. Shamberger, M. J. Ammer, C. Guo, S. Li, R. Shah, T. Tuan, M. Sheets, J. M. Rabaey, B. Nikolic, *et al.*, "Design methodology for picoradio networks," in *Proceedings of Conference and Exhibition on Design, Automation and Test in Europe*, 2001, pp. 314–323.
- [12] K. Langendoen and G. Halkes, "Energy-efficient medium access control," *Embedded systems handbook*, pp. 34–1, 2005.
- [13] O. B. Akan, O. B. Karli, and O. Ergul, "Cognitive radio sensor networks," *IEEE network*, vol. 23, no. 4, pp. 34–40, 2009.
- [14] B. Shrestha, E. Hossain, and S. Camorlinga, "Hidden node collision mitigated csma/ca-based multihop wireless sensor networks," in *IEEE International Conference on Communications (ICC)*. IEEE, 2013, pp. 1570–1575.
- [15] D. Niyato, E. Hossain, M. M. Rashid, and V. K. Bhargava, "Wireless sensor networks with energy harvesting technologies: A game-theoretic approach to optimal energy management," *IEEE Wireless Communications*, vol. 14, no. 4, pp. 90–96, 2007.
- [16] D. Niyato, E. Hossain, and A. Fallahi, "Analysis of different sleep and wakeup strategies in solar powered wireless sensor networks," in *IEEE International Conference on Communications*, vol. 7. IEEE, 2006, pp. 3333–3338.
- [17] D. Djenouri and M. Bagaa, "Energy harvesting aware relay node addition for power-efficient coverage in wireless sensor networks," in *2015 IEEE International Conference on Communications (ICC)*. IEEE, 2015, pp. 86–91.
- [18] M. Douadou, D. Djenouri, and N. Badache, "Survey on latency issues of asynchronous mac protocols in delay-sensitive wireless sensor networks," *IEEE Communications Surveys & Tutorials*, vol. 15, no. 2, pp. 528–550, 2013.
- [19] D. Djenouri and I. Balasingham, "Traffic-differentiation-based modular qos localized routing for wireless sensor net-

- works,” *IEEE Trans. Mob. Comput.*, vol. 10, no. 6, pp. 797–809, 2011.
- [20] K. R. Chowdhury, N. Nandiraju, D. Cavalcanti, and D. P. Agrawal, “Cmac-a multi-channel energy efficient mac for wireless sensor networks,” in *IEEE Wireless Communications and Networking Conference (WCNC)*, vol. 2, 2006, pp. 1172–1177.
- [21] N. S. Mazloum and O. Edfors, “Dcw-mac: An energy efficient medium access scheme using duty-cycled low-power wake-up receivers,” in *IEEE Vehicular Technology Conference (VTC Fall)*, 2011, pp. 1–5.
- [22] A. Bachir, M. Dohler, T. Watteyne, and K. K. Leung, “Mac essentials for wireless sensor networks,” *IEEE Communications Surveys & Tutorials*, vol. 12, no. 2, pp. 222–248, 2010.
- [23] P. Huang, L. Xiao, S. Soltani, M. M.W., and N. Xi, “The evolution of mac protocols in wireless sensor networks: A survey,” *IEEE Communications Surveys & Tutorials*, vol. 15, no. 1, pp. 101–120, 2013.
- [24] M. M. H. Khanafer, M.; Guennoun, “A survey of beacon-enabled ieee 802.15.4 mac protocols in wireless sensor networks,” *IEEE Communications Surveys & Tutorials*, vol. 16, no. 2, pp. 856–876, 2014.
- [25] L. Song and D. Hatzinakos, “A cross-layer architecture of wireless sensor networks for target tracking,” *IEEE/ACM Transactions on Networking*, vol. 15, no. 1, pp. 145–158, 2007.
- [26] I. Khalil, S. Bagchi, and N. B. Shroff, “Slam: sleep-wake aware local monitoring in sensor networks,” in *37th Annual IEEE/IFIP International Conference on Dependable Systems and Networks (DSN)*, 2007, pp. 565–574.
- [27] E.-Y. Lin, J. M. Rabaey, A. Wolisz, *et al.*, “Power-efficient rendez-vous schemes for dense wireless sensor networks,” in *IEEE International Conference on Communications*, vol. 7, 2004, pp. 3769–3776.
- [28] R. C. Carrano, D. Passos, L. Magalhaes, and C. V. Albuquerque, “Survey and taxonomy of duty cycling mechanisms in wireless sensor networks,” *IEEE Communications Surveys & Tutorials*, vol. 16, no. 1, pp. 181–194, 2014.
- [29] G. Anastasi, M. Conti, M. Di Francesco, and A. Passarella, “Energy conservation in wireless sensor networks: A survey,” *Ad hoc networks*, vol. 7, no. 3, pp. 537–568, 2009.
- [30] V. Jelcic, M. Magno, D. Brunelli, V. Bilas, and L. Benini, “Analytic comparison of wake-up receivers for wsns and benefits over the wake-on radio scheme,” in *Proceedings of the 7th ACM workshop on Performance monitoring and measurement of heterogeneous wireless and wired networks*, 2012, pp. 99–106.
- [31] Y. Zhang, L. Huang, G. Dolmans, and H. De Groot, “An analytical model for energy efficiency analysis of different wakeup radio schemes,” in *IEEE 20th International Symposium on Personal, Indoor and Mobile Radio Communications*, 2009, pp. 1148–1152.
- [32] I. Demirkol, C. Ersoy, and E. Onur, “Wake-up receivers for wireless sensor networks: benefits and challenges,” *IEEE Wireless Communications*, vol. 16, no. 4, pp. 88–96, 2009.
- [33] M. Nosovic and T. D. Todd, “Scheduled rendezvous and rfid wakeup in embedded wireless networks,” in *IEEE International Conference on Communications (ICC)*, vol. 5. IEEE, 2002, pp. 3325–3329.
- [34] M. J. Miller and N. H. Vaidya, “Minimizing energy consumption in sensor networks using a wakeup radio,” in *IEEE Wireless Communications and Networking Conference (WCNC)*, vol. 4, 2004, pp. 2335–2340.
- [35] —, “Power save mechanisms for multi-hop wireless networks,” in *Proceedings of the 1st International Conference on Broadband Networks*. IEEE, 2004, pp. 518–526.
- [36] A. G. Ruzzelli, R. Jurdak, and G. M. O’Hare, “On the rfid wake-up impulse for multi-hop sensor networks,” in *The 1st ACM Workshop on Convergence of RFID and Wireless Sensor Networks and their Applications (SenseID) at the 5th ACM International Conference on Embedded Networked Sensor Systems (ACM SenSys)*, Sydney, Australia, November 04–09, 2007.
- [37] M. A. Malik, B.-H. Lee, Y.-B. Ko, and J.-H. Kim, “Minimum energy and latency mac protocol for wireless sensor networks,” in *Ubiquitous Intelligence and Computing*. Springer, 2007, pp. 444–453.
- [38] G. Zheng, J. Fu, S. Tang, Y. Li, and Z. Dong, “A dual channel-based energy efficient and low latency mac protocol for wsns,” in *2nd International Conference on Networks Security Wireless Communications and Trusted Computing (NSWCTC)*, vol. 1, 2010, pp. 466–469.
- [39] F. A. Aoudia, M. Gautier, and O. Berder, “Opwum: Opportunistic mac protocol leveraging wake-up receivers in wsns,” *Journal of sensors*, vol. 2016, Article ID 6263719, 9 pages, 2016.
- [40] M. Buettner, G. V. Yee, E. Anderson, and R. Han, “X-mac: a short preamble mac protocol for duty-cycled wireless sensor networks,” in *Proceedings of the 4th ACM international conference on Embedded networked sensor systems*, 2006, pp. 307–320.
- [41] M. Lont, D. Milosevic, P. G. Baltus, A. H. Van Roermund, and G. Dolmans, “Analytical models for the wake-up receiver power budget for wireless sensor networks,” in *IEEE Global Telecommunications Conference (GLOBECOM)*, 2009, pp. 1–6.
- [42] R. Su, T. Watteyne, and K. S. Pister, “Comparison between preamble sampling and wake-up receivers in wireless sensor networks,” in *IEEE Global Telecommunications Conference (GLOBECOM 2010)*, 2010, pp. 1–5.
- [43] G. U. Gamm and L. M. Reindl, “Range extension for wireless wake-up receivers,” in *9th International Multi-Conference on Systems, Signals and Devices (SSD)*. IEEE, 2012, pp. 1–4.
- [44] J. Oller, I. Demirkol, J. Casademont, J. Paradells, G. U. Gamm, and L. Reindl, “Wake-up radio as an energy-efficient alternative to conventional wireless sensor networks mac protocols,” in *Proceedings of the 16th ACM international conference on Modeling, analysis & simulation of wireless and mobile systems*, 2013, pp. 173–180.
- [45] J. Polastre, J. Hill, and D. Culler, “Versatile low power media access for wireless sensor networks,” in *Proceedings of the 2nd ACM international conference on Embedded networked sensor systems*, 2004, pp. 95–107.
- [46] IEEE, IEEE Std 802.15.4-2006: Wireless Medium Access Control (MAC) and Physical Layer (PHY) Specifications for Low-Rate Wireless Personal Area Networks (WPANs) IEEE Std., September 2006.
- [47] M. Ram and S. Kumar, “Analytical energy consumption model for mac protocols in wireless sensor networks,” in *IEEE International Conference on Signal Processing and Integrated Networks (SPIN)*, 2014, pp. 444–447.
- [48] G. Lu, B. Krishnamachari, and C. S. Raghavendra, “An adaptive energy-efficient and low-latency mac for data gathering in wireless sensor networks,” in *Proceedings of the 18th IEEE International Parallel and Distributed Processing Symposium*, 2004, pp. 26–30.
- [49] M. Magno, S. Marinkovic, B. Srbinovski, and E. Popovici, “Wake-up radio receiver based power minimization techniques for wireless sensor networks: A review,” *Microelectronics Journal*, vol. 45, no. 12, pp. 1627–1633, 2014.
- [50] N. S. Mazloum and O. Edfors, “Performance analysis and energy optimization of wake-up receiver schemes for wireless low-power applications,” *IEEE Transactions on Wireless Communications*, vol. 13, no. 12, pp. 7050–7061, 2014.
- [51] B. J. van der Zwaag, N. Meratnia, P. J. Havinga, *et al.*, “Evaluation of mac protocols with wake-up radio for implantable body sensor networks,” *Procedia Computer Science*, vol. 40, pp. 173–180, 2014.
- [52] D. Djenouri and M. Bagaa, “Synchronization protocols and implementation issues in wireless sensor networks: A review,” *IEEE Systems Journal*, vol. 10, no. 2, pp. 617–627, 2016.
- [53] B. P. Otis, “Ultra-low power wireless technologies for sensor networks,” Ph.D. dissertation, Citeseer, 2005.
- [54] J. M. Rabaey, J. Ammer, T. Karalar, S. Li, B. Otis, M. Sheets, and T. Tuan, “Picoradios for wireless sensor networks: the next challenge in ultra-low power design,” in *IEEE International Solid-State Circuits Conference (ISSCC)*, vol. 1, 2002, pp. 200–201.

- [55] S. Marinkovic and E. Popovici, "Nano-power wake-up radio circuit for wireless body area networks," in *IEEE Radio and Wireless Symposium (RWS)*, 2011, pp. 398–401.
- [56] S. J. Marinkovic and E. M. Popovici, "Nano-power wireless wake-up receiver with serial peripheral interface," *IEEE Journal on Selected Areas in Communications*, vol. 29, no. 8, pp. 1641–1647, 2011.
- [57] D.-Y. Yoon, C.-J. Jeong, J. Cartwright, H.-Y. Kang, S.-K. Han, N.-S. Kim, D.-S. Ha, and S.-G. Lee, "A new approach to low-power and low-latency wake-up receiver system for wireless sensor nodes," *IEEE Journal of Solid-State Circuits*, vol. 47, no. 10, pp. 2405–2419, 2012.
- [58] L. Gu and J. A. Stankovic, "Radio-triggered wake-up for wireless sensor networks," *Real-Time Systems*, vol. 29, no. 2-3, pp. 157–182, 2005.
- [59] L. Gu, J. A. Stankovic, et al., "Radio-triggered wake-up capability for sensor networks," in *IEEE Real-Time and Embedded Technology and Applications Symposium*, 2004, pp. 27–37.
- [60] A. P. Sample, D. J. Yeager, P. S. Powlledge, and J. R. Smith, "Design of a passively-powered, programmable sensing platform for uhf rfid systems," in *IEEE International Conference on RFID*, 2007, pp. 149–156.
- [61] H. Ba, I. Demirkol, and W. Heinzelman, "Feasibility and benefits of passive rfid wake-up radios for wireless sensor networks," in *IEEE Global Telecommunications Conference (GLOBECOM)*, 2010, pp. 1–5.
- [62] P. Nintanavongsa, U. Muncuk, D. R. Lewis, and K. R. Chowdhury, "Design optimization and implementation for rf energy harvesting circuits," *IEEE Journal on Emerging and Selected Topics in Circuits and Systems*, vol. 2, no. 1, pp. 24–33, 2012.
- [63] L. Chen, S. Cool, H. Ba, W. Heinzelman, I. Demirkol, U. Muncuk, K. Chowdhury, and S. Basagni, "Range extension of passive wake-up radio systems through energy harvesting," in *IEEE International Conference on Communications (ICC)*, 2013, pp. 1549–1554.
- [64] M. Malinowski, M. Moskwa, M. Feldmeier, M. Laibowitz, and J. A. Paradiso, "Cargonet: a low-cost micropower sensor node exploiting quasi-passive wakeup for adaptive asynchronous monitoring of exceptional events," in *Proceedings of the 5th international conference on Embedded networked sensor systems*. ACM, 2007, pp. 145–159.
- [65] P. Kolinko and L. Larson, "Passive rf receiver design for wireless sensor networks," in *Microwave Symposium, 2007. IEEE/MTT-S International*, 2007, pp. 567–570.
- [66] P. Le-Huy and S. Roy, "Low-power 2.4 ghz wake-up radio for wireless sensor networks," in *IEEE International Conference on Wireless and Mobile Computing Networking and Communications (WiMob)*, 2008, pp. 13–18.
- [67] J. Ansari, D. Pankin, and P. Mähönen, "Radio-triggered wake-ups with addressing capabilities for extremely low power sensor network applications," *International Journal of Wireless Information Networks*, vol. 16, no. 3, pp. 118–130, 2009.
- [68] G. U. Gamm, M. Sippel, M. Kostic, and L. M. Reindl, "Low power wake-up receiver for wireless sensor nodes," in *6th IEEE International Conference on Intelligent Sensors, Sensor Networks and Information Processing (ISSNIP)*, 2010, pp. 121–126.
- [69] A. Sanchez, J. Aguilar, S. Blanc, and J. Serrano, "Rfid-based wake-up system for wireless sensor networks," in *SPIE Microtechnologies*, vol. 806708. International Society for Optics and Photonics, doi:10.1117/12.887039, 2011.
- [70] J. Oller, I. Demirkol, J. Paradells, J. Casademont, and W. Heinzelman, "Time-knocking: A novel addressing mechanism for wake-up receivers," in *8th IEEE International Conference on Wireless and Mobile Computing, Networking and Communications (WiMob)*, 2012, pp. 268–275.
- [71] J. Oller, I. Demirkol, J. Casademont, and J. Paradells, "Design, development, and performance evaluation of a low-cost, low-power wake-up radio system for wireless sensor networks," *ACM Transactions on Sensor Networks (TOSN)*, vol. 10, no. 1, p. 11:1–11:24, 2013.
- [72] B. Van der Doorn, W. Kavelaars, and K. Langendoen, "A prototype low-cost wakeup radio for the 868 mhz band," *International Journal of Sensor Networks*, vol. 5, no. 1, pp. 22–32, 2009.
- [73] S. Von der Mark, R. Kamp, M. Huber, and G. Boeck, "Three stage wakeup scheme for sensor networks," in *SBMO/IEEE MTT-S International Conference on Microwave and Optoelectronics*. IEEE, 2005, pp. 205–208.
- [74] M. Miladi, T. Ezzedine, and R. Bouallegue, "Latency of energy efficient mac protocols for wireless sensor networks," in *International Conference on Digital Telecommunications (ICDT)*, 2006, pp. 60–65.
- [75] C. Zhou and T. Zhu, "Thorough analysis of mac protocols in wireless sensor networks," in *4th International Conference on Wireless Communications, Networking and Mobile Computing*, 2008, pp. 1–4.
- [76] W. Ye, J. Heidemann, and D. Estrin, "An energy-efficient mac protocol for wireless sensor networks," in *Proceedings of 21st Annual Joint Conference of the IEEE Computer and Communications Societies (INFOCOM)*, vol. 3, 2002, pp. 1567–1576.
- [77] T. Van Dam and K. Langendoen, "An adaptive energy-efficient mac protocol for wireless sensor networks," in *Proceedings of the 1st international conference on Embedded networked sensor systems*. ACM, 2003, pp. 171–180.
- [78] C. Schurgers, V. Tsiatsis, S. Ganeriwal, and M. Srivastava, "Topology management for sensor networks: Exploiting latency and density," in *Proceedings of the 3rd ACM international symposium on Mobile ad hoc networking & computing*. ACM, 2002, pp. 135–145.
- [79] S. C. Ergen and P. Varaiya, "Pedamacs: Power efficient and delay aware medium access protocol for sensor networks," *IEEE Transactions on Mobile Computing*, vol. 5, no. 7, pp. 920–930, 2006.
- [80] V. Rajendran, K. Obraczka, and J. J. Garcia-Luna-Aceves, "Energy-efficient, collision-free medium access control for wireless sensor networks," *Wireless Networks*, vol. 12, no. 1, pp. 63–78, 2006.
- [81] L. F. Van Hoesel and P. J. Havinga, "A lightweight medium access protocol (lmac) for wireless sensor networks: Reducing preamble transmissions and transceiver state switches," in *1st International Workshop on Networked Sensing Systems (INSS)*. Society of Instrument and Control Engineers (SICE), June 22–23, 2004, Tokyo, Japan, pp. 205–208.
- [82] K. Arisha, M. Youssef, and M. Younis, "Energy-aware tdma-based mac for sensor networks," in *System-level power optimization for wireless multimedia communication*. Springer, 2002, pp. 21–40.
- [83] I. Rhee, A. Warriar, M. Aia, J. Min, and M. L. Sichitiu, "Z-mac: a hybrid mac for wireless sensor networks," *IEEE/ACM Transactions on Networking (TON)*, vol. 16, no. 3, pp. 511–524, 2008.
- [84] G.-S. Ahn, S. G. Hong, E. Miluzzo, A. T. Campbell, and F. Cuomo, "Funneling-mac: a localized, sink-oriented mac for boosting fidelity in sensor networks," in *Proceedings of the 4th international conference on Embedded networked sensor systems*. ACM, 2006, pp. 293–306.
- [85] C. Schurgers, V. Tsiatsis, S. Ganeriwal, and M. Srivastava, "Optimizing sensor networks in the energy-latency-density design space," *IEEE Transactions on Mobile Computing*, vol. 1, no. 1, pp. 70–80, 2002.
- [86] J. Ansari, X. Zhang, and P. Mahonen, "Multi-radio medium access control protocol for wireless sensor networks," *International Journal of Sensor Networks*, vol. 8, no. 1, pp. 47–61, 2010.
- [87] A. Bachir, D. Barthel, M. Heusse, and A. Duda, "Micro-frame preamble mac for multihop wireless sensor networks," in *IEEE International Conference on Communications (ICC)*, vol. 7, 2006, pp. 3365–3370.
- [88] A. El-Hoiydi and J.-D. Decotignie, "Wisemac: an ultra low power mac protocol for the downlink of infrastructure wireless sensor networks," in *Proceedings of the 9th IEEE International Symposium on Computers and Communications (ISCC)*, vol. 1, 2004, pp. 244–251.

- [89] S. Mahlknecht and M. Böck, "Csma-mps: a minimum preamble sampling mac protocol for low power wireless sensor networks," in *Proceedings of IEEE International Workshop on Factory Communication Systems*, 2004, pp. 73–80.
- [90] M. J. Miller and N. H. Vaidya, "A mac protocol to reduce sensor network energy consumption using a wakeup radio," *IEEE Transactions on Mobile Computing*, vol. 4, no. 3, pp. 228–242, 2005.
- [91] A. Khatibi, Y. Durmuş, E. Onur, and I. Niemegeers, "Event-driven mac protocol for dual-radio cooperation," in *IEEE Vehicular Technology Conference (VTC Fall)*. IEEE, 2012, pp. 1–5.
- [92] R. Jurdak, A. G. Ruzzelli, and G. M. O'Hare, "Radio sleep mode optimization in wireless sensor networks," *IEEE Transactions on Mobile Computing*, vol. 9, no. 7, pp. 955–968, 2010.
- [93] —, "Adaptive radio modes in sensor networks: How deep to sleep?" in *5th Annual IEEE Communications Society Conference on Sensor, Mesh and Ad Hoc Communications and Networks (SECON)*, 2008, pp. 386–394.
- [94] C. Guo, L. Zhong, and J. M. Rabaey, "Low power distributed mac for ad hoc sensor radio networks," in *IEEE Global Telecommunications Conference (GLOBECOM)*, vol. 5. IEEE, 2001, pp. 2944–2948.
- [95] K. R. Chowdhury, N. Nandiraju, P. Chanda, D. P. Agrawal, and Q.-A. Zeng, "Channel allocation and medium access control for wireless sensor networks," *Ad Hoc Networks*, vol. 7, no. 2, pp. 307–321, 2009.
- [96] N. Ullah, M. S. Chowdhury, M. Al Ameen, and K. S. Kwak, "Energy efficient mac protocol for low-energy critical infrastructure monitoring networks using wakeup radio," *International Journal of Distributed Sensor Networks*, vol. 2012, Article ID 504946, 15 pages, 2012.
- [97] N. Ullah, M. S. Chowdhury, P. Khan, and K. S. Kwak, "Multi-hop medium access control protocol for low energy critical infrastructure monitoring networks using wakeup radio," *International Journal of Communication Systems*, vol. 27, no. 11, pp. 2536–2554, 2014.
- [98] T. N. Le, A. Pegatoquet, and M. Magno, "Asynchronous on demand mac protocol using wake-up radio in wireless body area network," in *6th IEEE International Workshop on Advances in Sensors and Interfaces (IWASI)*, 2015, pp. 228–233.
- [99] K. Ravichandran, K. Sivalingam, and P. Agrawal, "Design and analysis of a dual radio node architecture and medium access control protocols for ultra wide band based sensor networks," in *4th IEEE International Conference on Broadband Communications, Networks and Systems*, 2007, pp. 889–897.
- [100] R. Jurdak, A. G. Ruzzelli, and G. M. Hare, "Multi-hop rfid wake-up radio: design, evaluation and energy tradeoffs," in *Proceedings of 17th IEEE International Conference on Computer Communications and Networks (ICCCN)*, 2008, pp. 1–8.
- [101] P. Sthapit and J.-Y. Pyun, "Effects of radio triggered sensor mac protocol over wireless sensor network," in *11th IEEE International Conference on Computer and Information Technology (CIT)*, 2011, pp. 546–551.
- [102] N. Ullah, P. Khan, and K. S. Kwak, "A very low power mac (vlpm) protocol for wireless body area networks," *Sensors*, vol. 11, no. 4, pp. 3717–3737, 2011.
- [103] M. A. Ameen, N. Ullah, M. S. Chowdhury, and K. Kwak, "A mac protocol for body area networks using out-of-band radio," in *11th European Wireless Conference Sustainable Wireless Technologies (European Wireless)*, 2011, pp. 1–6.
- [104] M. Al Ameen, N. Ullah, M. S. Chowdhury, S. R. Islam, and K. Kwak, "A power efficient mac protocol for wireless body area networks," *EURASIP Journal on Wireless Communications and Networking*, no. 1, pp. 1–17, 2012.
- [105] P. Sthapit and J.-Y. Pyun, "Passive synchronization based energy-efficient mac protocol over m2m wireless networks," *International Journal of Distributed Sensor Networks*, vol. 2013, Article ID 871607, 12 pages, 2013.
- [106] T. N. Le, M. Magno, A. Pegatoquet, O. Berder, O. Sentieys, and E. Popovici, "Ultra low power asynchronous mac protocol using wake-up radio for energy neutral wsn," in *Proceedings of the 1st International Workshop on Energy Neutral Sensing Systems*. ACM, 2013, pp. 10:1–10:6.
- [107] M. Magno, S. Marinkovic, D. Brunelli, E. Popovici, B. O'Flynn, and L. Benini, "Smart power unit with ultra low power radio trigger capabilities for wireless sensor networks," in *Proceedings of the Conference on Design, Automation and Test in Europe*. EDA Consortium, 2012, pp. 75–80.
- [108] T. N. Le, A. Pegatoquet, O. Sentieys, O. Berder, and C. Belleudy, "Duty-cycle power manager for thermal-powered wireless sensor networks," in *24th IEEE International Symposium on Personal Indoor and Mobile Radio Communications (PIMRC)*, 2013, pp. 1645–1649.
- [109] J. Lebreton and N. Murad, "Implementation of a wake-up radio cross-layer protocol in omnet++/mixim," *Proceedings of the 2nd OMNeT++ Community Summit*, 2015.
- [110] S. H. Lee, Y. S. Bae, and L. Choi, "On-demand radio wave sensor for wireless sensor networks: Towards a zero idle listening and zero sleep delay mac protocol," in *IEEE Global Communications Conference (GLOBECOM)*, 2012, pp. 560–566.
- [111] IEEE Std. 802.11-2007, Part 11: Wireless LAN Medium Access Control (MAC) and Physical Layer (PHY) specifications," IEEE Std. 802.11, 2007.
- [112] E. Umbdenstock, F. Schäfer, M. Kleinstüber, and H. Meyer, "Wake-up-receiver in energy efficient wireless sensor networks for security applications," in *Proceedings of the 7th edition of the Interdisciplinary Workshop on Global Security*, 2013.
- [113] Austriamicrosystems: AS3932 3D Low Frequency Wakeup Receiver Datasheet v1.
- [114] F. Dressler, B. Bloessl, M. Hierold, C.-Y. Hsieh, T. Nowak, R. Weigel, and A. Koelplin, "Protocol design for ultra-low power wake-up systems for tracking bats in the wild," in *IEEE International Conference on Communications (ICC)*, 2015, pp. 6345–6350.
- [115] X. Yang and N. H. Vaidya, "A wakeup scheme for sensor networks: Achieving balance between energy saving and end-to-end delay," in *Proceedings of the 10th IEEE Real-Time and Embedded Technology and Applications Symposium (RTAS)*. IEEE, 2004, pp. 19–26.
- [116] M. Dhanaraj, B. Manoj, and C. Murthy, "A new energy efficient protocol for minimizing multi-hop latency in wireless sensor networks," in *3rd IEEE International Conference on Pervasive Computing and Communications (PerCom)*. IEEE, 2005, pp. 117–126.
- [117] I. M. Khalil, "Elmo: energy aware local monitoring in sensor networks," *IEEE Transactions on Dependable and Secure Computing*, vol. 8, no. 4, pp. 523–536, 2011.
- [118] T. Cevik, D. Yiltas, and A. H. Zaim, "Delay efficient stem by pipelining," *Procedia Computer Science*, vol. 3, pp. 96–103, 2011.
- [119] S. Basagni, C. Petrioli, and D. Spenza, "Ctp-wur: The collection tree protocol in wake-up radio wsns for critical applications," in *IEEE International Conference on Computing, Networking and Communications (ICNC)*, 2016, pp. 1–6.
- [120] J. Oller, I. Demirkol, J. Casademont, J. Paradells, G. U. Gamm, and L. Reindl, "Has time come to switch from duty-cycled mac protocols to wake-up radio for wireless sensor networks?" *IEEE/ACM Transactions on Networking*, vol. 24, no. 2, pp. 674–687, 2016.
- [121] Y. Sun, O. Gurewitz, and D. B. Johnson, "Ri-mac: a receiver-initiated asynchronous duty cycle mac protocol for dynamic traffic loads in wireless sensor networks," in *Proceedings of the 6th ACM conference on Embedded network sensor systems*, 2008, pp. 1–14.
- [122] I. Seyfettin Demirkol, J. Paradells Aspas, J. Oller Bosch, J. Casademont Serra, A. M. Calveras Augé, and M. L. Catalán Cid, "Energy efficient wireless networking of sensor nodes," in *AMA conferences proceedings: Nürnberg Exhibition Centre, Germany, 14-16. 5. 2013: with SENSOR, OPTO, IRS²*, 2013, pp. 452–456.
- [123] ITC Engineering, Stuttgart, Germany, "Research project IB-ISEB, Intelligent Bridges—Information System for Structure Monitoring and Maintenance, 2014 [Online]. Available: <http://www.itc-engineering.de/index.php?id=195L=1>.

- [124] M. Del Prete, D. Masotti, A. Costanzo, M. Magno, and L. Benini, "A dual-band wake-up radio for ultra-low power wireless sensor networks," in *IEEE Topical Conference on Wireless Sensors and Sensor Networks (WiSNet)*. IEEE, 2016, pp. 81–84.
- [125] M. Magno, V. Jelicic, B. Srbinovski, V. Bilas, E. Popovici, and L. Benini, "Design, implementation, and performance evaluation of a flexible low-latency nanowatt wake-up radio receiver," *IEEE Transactions on Industrial Informatics*, vol. 12, no. 2, pp. 633–644, 2016.
- [126] D. Spenza, M. Magno, S. Basagni, L. Benini, M. Paoli, and C. Petrioli, "Beyond duty cycling: wake-up radio with selective awakenings for long-lived wireless sensing systems," in *IEEE Conference on Computer Communications (INFOCOM)*, 2015, pp. 522–530.
- [127] T. Polonelli, M. Magno, and L. Benini, "An ultra-low power wake up radio with addressing and retransmission capabilities for advanced energy efficient mac protocols," in *15th ACM/IEEE International Conference on Information Processing in Sensor Networks (IPSN)*. IEEE, 2016, pp. 1–2.
- [128] G. A. Shah and O. B. Akan, "Performance analysis of csma-based opportunistic medium access protocol in cognitive radio sensor networks," *Ad Hoc Networks*, vol. 15, pp. 4–13, 2014.
- [129] —, "Cognitive adaptive medium access control in cognitive radio sensor networks," *IEEE Transactions on Vehicular Technology*, vol. 64, no. 2, pp. 757–767, 2015.