

A REDISCOVERED LIFE: A SELECTIVE ANNOTATED EDITION OF THE
LETTERS OF CAROLINE ELIZABETH NORTON,
1828–1877

ROSS BELSON

A thesis submitted in partial fulfilment of the requirements of the University of the
West of England, Bristol, for the degree of Doctor of Philosophy

A handwritten signature in cursive script that reads "Caroline Norton". The signature is written in black ink and is underlined with a single horizontal line.

Faculty of Arts and Cultural Industries, University of the West of England, Bristol
July 2016

ABSTRACT

This thesis is a selective and annotated edition of 157 of the 2200 extant letters by Caroline Elizabeth Norton currently known to be available in both the public and private domain, which have been collected and transcribed for the project. The selection includes both the first extant letter, dated 28 July [1828] and the last, written on 10 June 1877, five days before Caroline Norton's death. Norton's letters to Lord Melbourne already published in an annotated edition (see Bibliography) have not been included in the selection. The letters are grouped chronologically into five sections, each representing approximately a decade of the author's life. Each section concludes a chapter of commentaries outlining the key historical and political events of each period and providing a thematic analysis of how the letters, including the residual 92% of correspondence not selected for the edition, comment on aspects of Caroline Norton's life, beliefs, work, family, relationships and society. In particular, the discussion will focus on how the letters challenge existing notions in these areas and reflect on comparably under-investigated or almost entirely non-researched biographical topics, such as Norton's views on literature and other writers, her health, and the nature of her relationships with her family, particularly her son Brinsley, and other key individuals in her life, such as Mary Shelley, Edward Trelawny, Lord Melbourne and Sidney Herbert. The five chapters are preceded by an introduction consisting of eight sections: a brief biography, an outline of the methodology adopted for the thesis, a review of literature, an account of Norton's epistolary writing, major works and place in nineteenth century literature, examples of her literary writing, her relations with publishers and her involvement with elite women's political activism, 1830-57. Prior to the Introduction, the thesis features a preface, a statement of editorial principles, a list of abbreviations and short titles, family trees for the Sheridan, Seymour, Norton and Le Fanu families, and a chronology of Caroline Norton's life. The thesis concludes with a full bibliography, a detailed bibliographical index of recipients and sample facsimiles of four letters with accompanying transcripts and examples of Norton's poetry.

CONTENTS

Volume 1

Abstract	2
Contents	3
Preface	6
List of recipients	13
Editorial Principles and Procedures	16
Abbreviations and Short Titles	20
Family Trees	23
Timeline of Caroline Norton's life	26
Introduction:	
i. Brief biography	32
ii. Methodology	35
iii. Review of literature	38
iv. Norton's epistolary writing	42
v. Norton's major works and place in Nineteenth century literature	51
vi. Examples of Norton's literary writing	58
vii. Norton's relations with publishers	65
viii. Norton and elite women's political activism, 1830-57	75
Chapter 1: <i>Rise and Fall of a Literary Celebrity (1828-37)</i>	
i. Introduction	97
ii. Norton's work as an editor and lyricist	98
iii. The influence of the Shelley-Byron circle on Norton	101
iv. Conclusion	105
v. The Letters (July 1828-June 1837)	107
Chapter 2: <i>Infant Custody (1837-47)</i>	
i. Introduction	153
ii. Norton's successful child custody appeal	154
iii. Norton's relationships with Sidney Herbert and Lord Melbourne	157
iv. Norton's involvement in the Corn Law scandal	162
v. Relationships with and opinion of other writers	163
vi. Conclusion	166

vii. The Letters (August 1837-January 1847)	168
Volume 2	
Chapter 3: <i>'I do not ask for my rights' (1847-57)</i>	
i. Introduction	220
ii. 'Letters to the Mob'	221
iii. Health	223
iv. Philanthropy	224
v. <i>Thrapps vs Norton</i>	225
vi. The Norton feud: a reinterpretation	227
vii. Norton's relationship with her sons	232
viii. The Letters: – (April 1847-March 1857)	239
Chapter 4: <i>Novels and travails (1857-67)</i>	
i. Political views	284
ii. Views of other writers	288
iii. Friendship with Sir William Stirling-Maxwell	289
iv. Relationship with Brinsley Norton	291
v. Relationship with Georgia Seymour	298
vi. Health and literary career	303
vii. The Letters: – (February 1858-May 1867)	305
Chapter 5: <i>'This Unloved Creature' (1867-77)</i>	
i. Introduction	353
ii. Political views	354
iii. Health and Literary career	357
iv. Views of other writers	360
v. Second marriage	362
vi. Relationship with Brinsley Norton and her grandchildren	363
vii. Feud and reconciliation: relations with Georgia Seymour	367
viii. Relationships with servants	369
ix. Deaths in the family	371
x. Richard Norton's marriage	372
xi. The Letters: – (January 1868-June 1877)	375
Bibliography	422

Appendix 1: Biographical Index of Recipients	438
Appendix 2: Manuscript letters with example transcriptions	471

FAMILY TREE OF SHERIDAN, SEYMOUR AND LE FANU FAMILIES

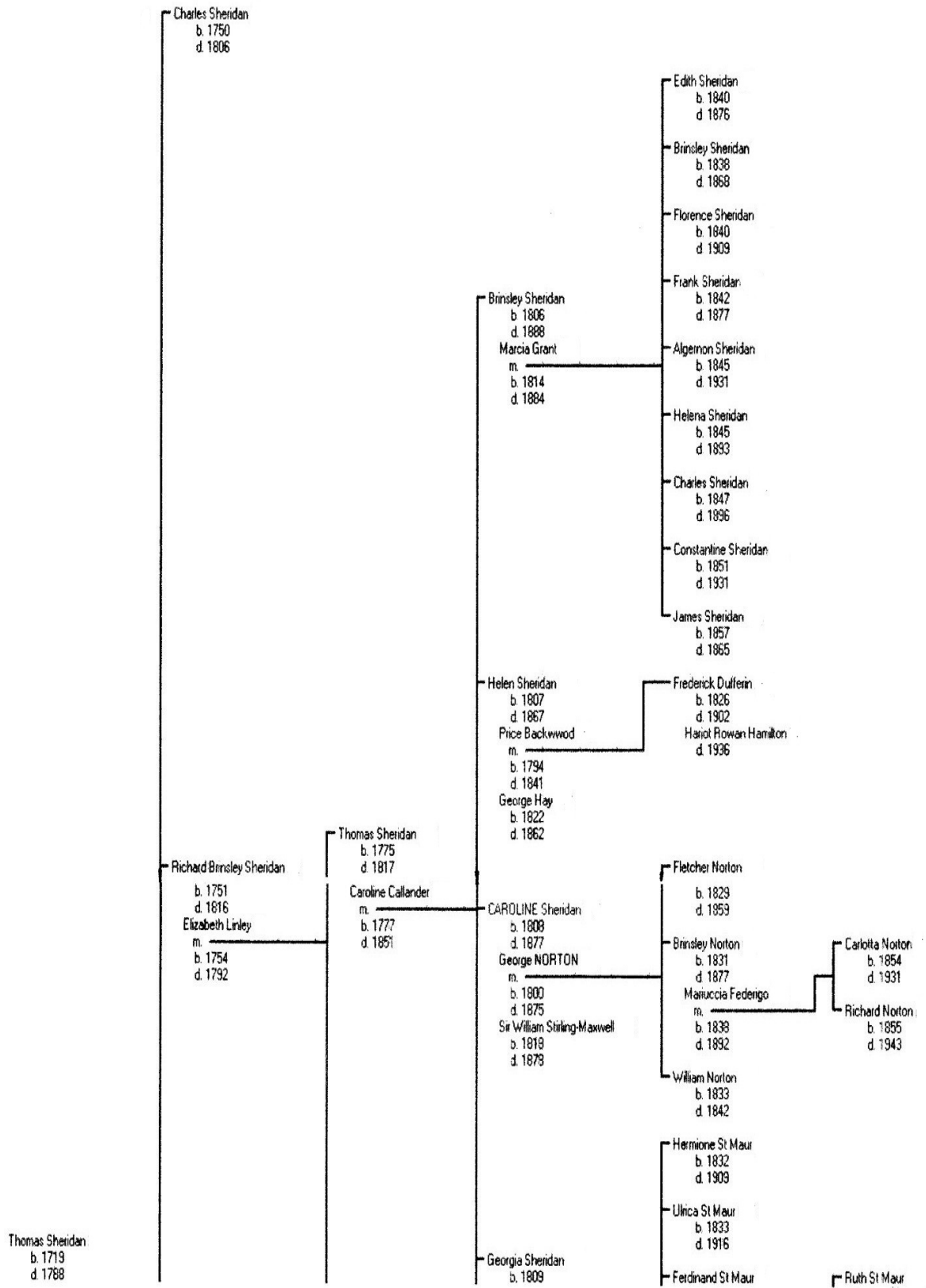

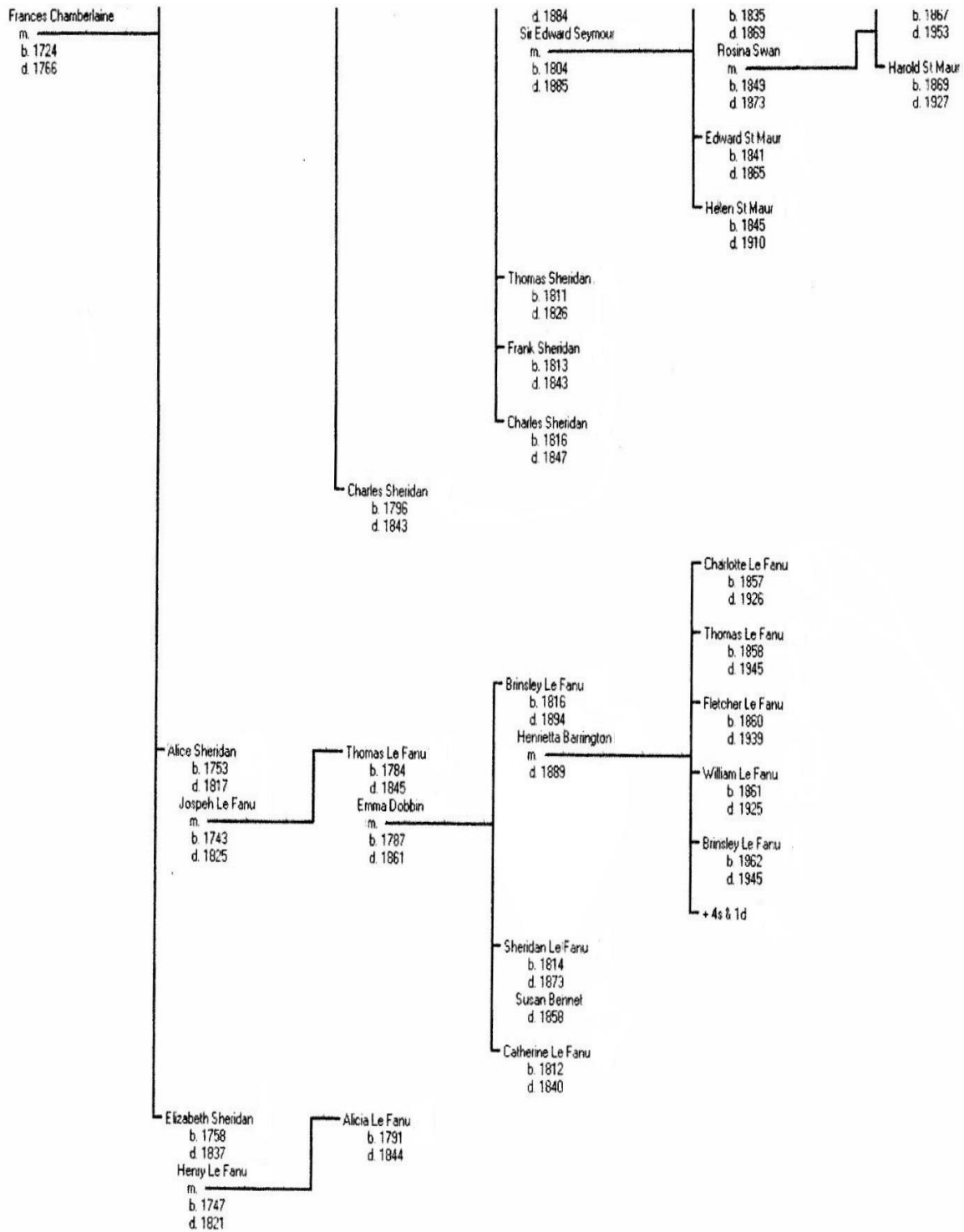

NORTON FAMILY TREE

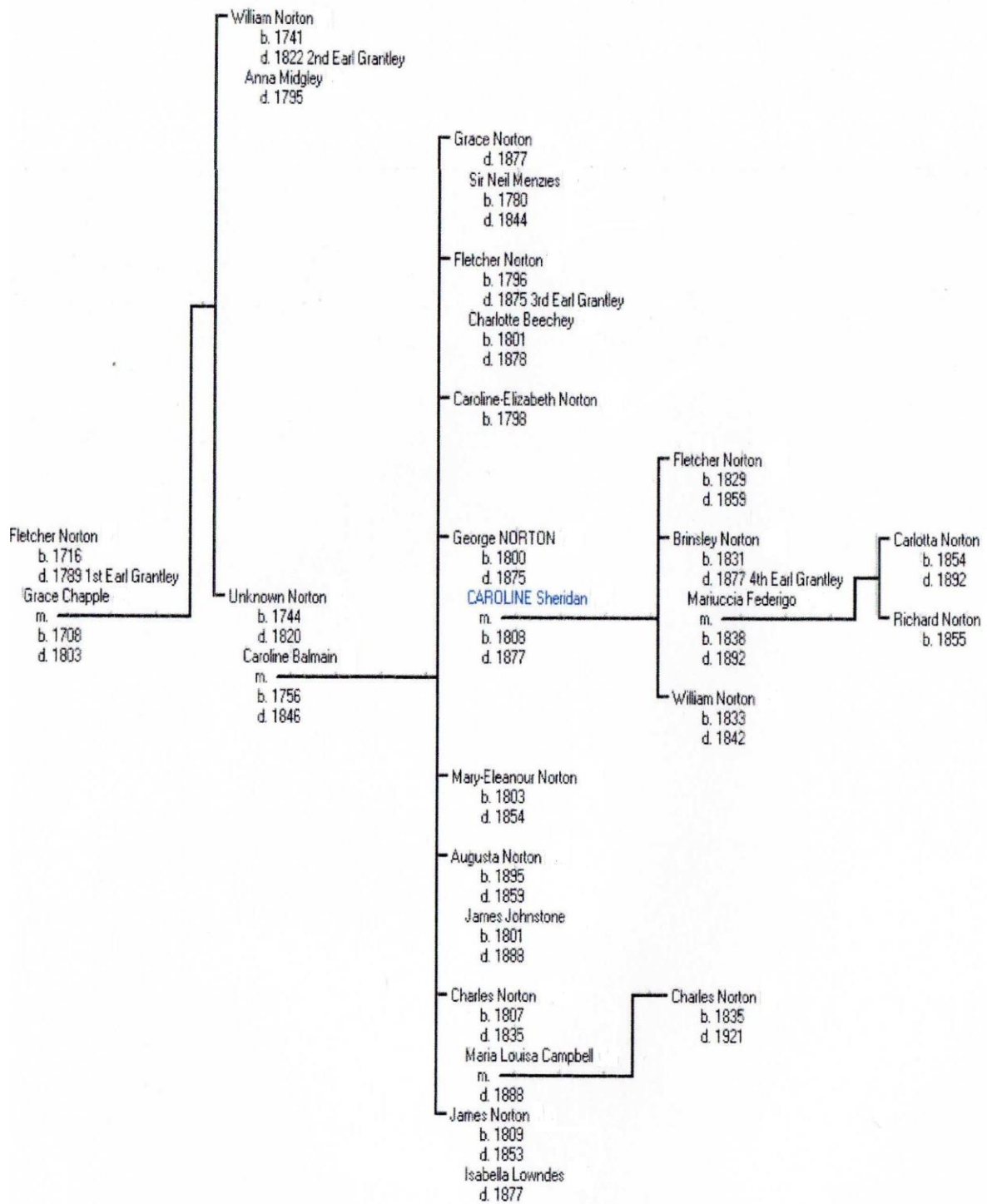

BIBLIOGRAPHY

Works by Caroline Norton:

1. Published Letters

Hoge, James O. and Olney, Clarke [eds.], *Letters from Caroline Norton to Lord Melbourne*, (Columbus: Ohio State University Press, 1974).

Latane, David E., Jr. [ed.], 'Two Letters of Caroline Norton to Charles Molloy Westmacott' (Notes & Queries, March 2005).

MacNachten, A. I. [ed.], 'Some Letters of Caroline Norton' in *Notes & Queries* (January, 1949).

Norton, Caroline [ed.], *Letters Etc. Dated from June 1836 to July 1841* (London: privately printed, 1841).

Rauchbauer, Otto Hans [ed.], 'Some unrecorded letters by Caroline Norton', *Notes and Queries* (September 1970).

2. Poetry

The Sorrows of Rosalie and Other Poems (London: John Ebers & Co, 1829).

The Undying One and Other Poems (London: H. Colburn & R. Bentley, 1830).

'The Last Look', *Friendships Offering* (1831), pp. 26–30.

'The Factory', *New Monthly Magazine*, 39.153 (September 1833), p. 17.

A Voice from the Factories (London: John Murray, 1836).

The Dream and Other Poems (London: Henry Colburn, 1840).

The Child of the Islands (London: Chapman & Hall, 1845).

The Lady of La Garaye (London: Macmillan & Co., 1862).

3. Fiction

The Coquette and Other Tales and Sketches, in Prose and Verse (London: John Bull, 1835).

The Wife, and Woman's Reward (1835).

Stuart of Dunleath (London: George Routledge & Sons, 1851).

Lost and Saved (London: Hurst & Blackett, 1863).

Old Sir Douglas (London: Hurst & Blackett, 1867).

4. Pamphlets and articles

A Letter to the Queen on Lord Chancellor Cranworth's Marriage & Divorce Bill (London: Longman, Brown, Green & Longman, 1855).

A Plain Letter to the Lord Chancellor on the Infant Custody Bill, by Pearce Stevenson (London: James Ridgeway, 1839).

'Books of Gossip: Sheridan and his Biographers', *Macmillan's Magazine*, 3.15 (January 1861), pp. 173-9.

English Laws for Women in the Nineteenth Century (London: privately published, 1854).

'Lady Duff Gordon and her Works', *Macmillan's Magazine*, September 1869, pp. 457-62.

Letters to the Mob (London: Thomas Bosworth, 1848).

Separation of Mother and Child by the Law of Custody of Infants Considered (London: Roake & Varty, 1838).

'Taxation by an Irresponsible Taxpayer', (London: privately published, 1874).

5. Editions (other than of Letters)

Huddlestone, Joan [ed.], *Caroline Norton's Defense*, (Chicago: Academy, 1982).

Lovesey, Oliver [ed.], *Victorian Social Activists' Novels* (London: Pickering & Chatto, 2011), vol. 1: *The Wife, and Woman's Reward* by Caroline Norton.

Shurbutt, S. Bailey [ed.], *The Wife, and Woman's Reward*; (Scholars' Fascimiles & Reprints, Delmar, 1988).

Wordsworth, Jonathan [ed.], *A Voice from the Factories* (Oxford: Woodstock Books, 1994).

Works about Caroline Norton

Acland, Alice, *Caroline Norton* (London, Constable, 1948).

Atkinson, Diane, *The Criminal Conversation of Mrs Norton* (London: Preface, 2012).

Belson, Ross, Review of Diane Atkinson, *The Criminal Conversation of Caroline Norton* (2012), published online in *Women's Writing*: <http://www.tandfonline.com/doi/full/10.1080/09699082.2015.1037817> (2015).

Chedzoy, Alan, *A Scandalous Woman, the Story of Caroline Norton* (London, Allison & Busby, 1992).

Coleridge, Hartley, 'The Dream and Other Poems', *Quarterly Review*, 66.132 (September 1840), pp. 374-418.

Craig, Randall, *The Narratives of Caroline Norton* (Basingstoke: Palgrave Macmillan, 2009).

Fitzgerald, Percy, *The Lives of the Sheridans*, 2 vols. (London, Richard Bentley & Sons, 1886).

Mitchell, Sally, 'The Narratives of Caroline Norton, by Randall Craig', *Victorian Studies*, vol. 53, N° 1 (Autumn 2010), pp. 151–2.

Norman, Sylva, *Termagent Lady*, *Times Literary Supplement* (31 July 1948), p. 427.

O' Cinneide, Muireann, *Aristocratic Women and the Literary Nation* (New York: Palgrave Macmillan, 2008).

Olney, Clarke, 'Caroline Norton to Lord Melbourne', *Victorian Studies* (March 1965), pp. 255–62.

Perkins, Jane Grey, *The Life of Mrs Norton* (London, John Murray, 1909).

Reynolds, K. D. 'Norton, Caroline Elizabeth Sarah (1808–1877)', *Oxford Dictionary of National Biography*, Oxford University Press, 2004; online edn, Sept 2014 [<http://www.oxforddnb.com/view/article/20339>, accessed 25 March 2016].

Walton, Sheila Marshall, 'Caroline Norton: An Interpretation of the biographical resources relating to her life' (MA, University of Buckingham, 2000).

Wroath, John, *Until They are Seven* (Winchester: Waterside Press, 1992).

Published Articles

Argyle, Gisella, 'George Meredith's Fictional Transformations of Female Life–Writings', *SEL Studies in English Literature 1500–1900*, Volume 49, Number 4, Autumn 2009, pp. 975–91.

Bulwer Lytton, Edward, 'Romance and Reality', *New Monthly Magazine*, (July 1831), pp. 545–51.

Cross, Máire and Bland, Caroline, 'Gender Politics: Breathing New Life into Old Letters', *Gender and Politics in the Age of Letter–Writing, 1750–2000*, Caroline Bland and Máire Cross [eds] (Aldershot: Ashgate, 2004), pp. 3–14.

Deschpande, Prachi, "The Making of an Indian Nationalist Archive: Lakshmi Bai Jhansi, and 1857", *Journal of Asian Studies*, Vol. 67 (August 2008), p. 856.

Dolin, Kieran, 'The Transfigurations of Caroline Norton', *Victorian Literature and Culture*, Vol 30, No. 2 (2002), pp. 503–527.

Fluhr, Nicole, 'The Letter and the Law, or How Caroline Norton (Re)Wrote Female Subjectivity', *Tulsa Studies in Women's Literature*, Volume 28, Number 1, Spring 2009, pp. 37–55.

Hämmerle, Christa, 'Requests, Complaints, Demands. Preliminary Thoughts on the Petitioning Letters of Lower-Class Austrian Women, 1865–1918', in *Gender and Politics in the Age of Letter-Writing, 1750–2000*, eds. Caroline Bland and Máire Cross (Aldershot: Ashgate, 2004), pp. 115–34.

Hunt, Leigh, 'The Tapiser's Tale', *Fraser's magazine for town and country*, 57.338 (Feb 1858), pp. 160-163.

Kelley, Philip, and Hudson, Ronald, 'Editing the Brownings' Correspondence: An Editorial Manual', *Browning Institute Studies*, vol. 9 (1981), pp. 141–60.

Kemble, John, 'Custody of Infants Bill', *British and Foreign Review, or European Quarterly Journal*, 7 (July–October 1838), pp. 269–411.

O' Cinneide', Muireann, *Victorian Studies*, vol. 52, N° 2 (Winter 2010), pp. 312–4.

Richards, Bernard, 'The Sources of Henry James's "Mrs Medwin"', *Notes and Queries* (June 1980), pp. 226–30.

Shelley[?], Mary W., 'Living Literary Characters, No II. The Honourable Mrs Norton', *New Monthly Magazine and Literary Journal*, 33 (February, 1831), pp. 180–1.

Steinbach, Susie, *Women in England, 1760-1914* (London: Phoenix, 2005).

Stone, Harry, "'Araby" and the Writings of James Joyce', *The Antioch Review*, vol. 25, No. 3, (Autumn 1965), pp. 375–410.

Newspapers and Magazines

The Age

The Amulet: A Christian and Literary Remembrancer

The Athenaeum

Atlantic Monthly

La Belle Assemblée: or Court and Fashionable Magazine

Bentleys' Miscellany

Birmingham Daily Post

Derby Mercury

Fisher's Drawing Room Scrapbook

Fraser's Magazine

Friendship's Offering

The Graphic
Law Magazine, or, Quarterly Review of Jurisprudence
Le Correspondant
London Daily News
Manchester Times
The Morning Chronicle
The Morning Post
National Review
The New Monthly Magazine
Pall Mall Gazette
The Preston Chronicle
Punch
Quarterly Review
The Satirist
Saturday Review
Saunders's News-Letter
Sheffield Independent, and Yorkshire and Derbyshire Advertiser
Spectator
The Standard
Surrey Advertiser
The Times
The Tonic Sol-fa Reporter

Websites

<http://www.anglicanhistory.org> (accessed 5 September 2014).

[http://www.gracesguide.co.uk/Summers and Ogle](http://www.gracesguide.co.uk/Summers%20and%20Ogle) (accessed 18 November 2015).

<http://www.history.ac.uk/publications/office/comms-bankrupts> (accessed 13 September 2014).

<http://www.historyofparliamentonline.org>, accessed 13 September 2014).

<http://www.marxists.org/history/etol/writers/carlin/1985/women/womensoc.html> (accessed 13 September 2014).

<http://www.oxforddnb.com> (*Oxford Dictionary of National Biography*) (all articles accessed 22 March 2016):

- Allen, C. J. W., 'Kelly, Sir Fitzroy Edward (1796-1880)'.
- Barker, G. F. R., 'Best, William Draper, first Baron Wynford (1767-1845)'.
- Bettany, G. T., 'Locock, Sir Charles, first baronet (1799-1875)'.

- Boase, G. C. ‘Copeland, Thomas (1781-1855)’.
- ——— ‘Peel, Sir Robert, third baronet (1822-1895)’.
- Brown, Andrew, ‘Lytton, Edward George Earle Lytton Bulwer, first Baron Lytton (1803-1873)’.
- Bynum, W. F., ‘Marshall, John (1818-1891)’.
- Carnall, Geoffrey, ‘Moore, Thomas (1779-1852)’.
- Chancellor, V. E., ‘Fox, Henry Edward, fourth Baron Holland of Holland and fourth Baron Holland of Foxley (1802-1859)’.
- Cust, L. H. . ‘Swinton, James Rannie (1816-1888)’.
- Davenport-Hines, Richard, ‘Milnes, Richard Monckton, first Baron Houghton (1809-1885)’.
- Dingley, Robert, ‘Horne, Richard Hengist (1802-1884)’.
- Ferrier, R. W., Dalley, Stephanie, ‘Rawlinson, Sir Henry Creswicke, first baronet (1810-1895)’.
- Finkelstein, David, ‘Pringle, Thomas (1789-1834)’.
- Goodwin, Gordon, ‘Greenacre, James (1785-1837)’.
- Hall, Edith, ‘Talfourd, Sir Thomas Noon (1795-1854)’.
- Harris, P. R., ‘Panizzi, Sir Anthony (1797-1879)’.
- Knight, Joseph, ‘Keeley, Mary Anne (1805-1899)’.
- Macartney, Hilary ‘Maxwell, Sir William Stirling, ninth baronet (1818-1878)’.
- Mandler, Peter, ‘Hall, Anna Maria (1800-1881)’.
- ——— ‘Hall, Samuel Carter (1800-1889)’.
- ——— ‘Lamb, William, second Viscount Melbourne (1779-1848)’.
- McDowell, R. B., ‘Burgh, Ulick John de, first marquess of Clanricarde (1802-1874)
- Millar, Gordon F., ‘Ellice, Edward (1783-1863)’.
- Munsell, Darrell, ‘Clinton, Henry Pelham Fiennes Pelham-, fifth duke of Newcastle under Lyme (1811-1864)’.
- Ostrom, Hans, ‘Moxon, Edward (*bap.* 1801, *d.* 1858)’.
- Patten, Robert L., ‘Bentley, Richard (1794-1871)’.
- Polasky, Janet L., ‘Leopold I (1790-1865)’.
- Pollard, A. F., ‘Temple, William Francis Cowper-, Baron Mount-Temple (1811-1888)’.
- Power, D'A., ‘Hewett, Sir Prescott Gardner, first baronet (1812-1891)’.
- Reynolds, K. D., ‘Conyngham , Elizabeth, Marchioness Conyngham (1769-1861)’.
- ——— ‘Scott, Walter Francis Montagu-Douglas-, fifth duke of Buccleuch and seventh duke of Queensberry (1806-1884)’.
- Smith, G. B., ‘Graham, James, fourth duke of Montrose (1799-1874)’.
- Steele, David, ‘Temple, Henry John, third Viscount Palmerston (1784-1865)’.
- Zachs, William, Isaac, Peter, Fraser, Angus and Lister, William, ‘Murray family (*per.* 1768-1967)’.

<http://www.the-saleroom.com/en-gb/auction-catalogues/spink/catalogue-id-2906155/lot-22051186> (accessed 13 September 2014).

http://www.timeocean.com/Auction/detail_5548023.html (accessed 13 September 2014).

Published Works

Acosta-Hughes, Benjamin and Stephens, Susan A., *Callimachus in Context: From Plato to the Augustan Poets* (Cambridge: Cambridge University Press, 2012).

Airlie, Mabell, Countess of, *Lady Palmerston and her Times* (London: Hodder & Stoughton, 1922).

Anderson, George K., *The Legend of the Wandering Jew* (Providence: Brown University Press, 1991).

Anon, *The trial of John Peltier esq., for a libel against Napoleon Buonaparté, first consul of the French Republic, at the Court of King's-bench, Middlesex, on Monday the 21st of February, 1803* (London, Cox & Sons, 1803).

——— *Merriam-Webster's Medical Dictionary* (Springfield: Merriam-Webster, 1995).

——— *The Important and Eventful trial of Queen Caroline, Consort of George IV for "adulterous intercourse" with Bartolomo BCami, Parts 1-2* (London: Geo Smeeton, 1820).

Anstie, Francis, *The Practitioner*, (London: Macmillan & Co, 1870), vol. 5.

Austen, Jane, *Pride and Prejudice*, 3 vols. (London: T. Egerton, 1819).

Balzac, Honoré de, *La Peau de Chagrin, roman philosophique*, 2 vols. (Paris, 1831).

Belloc, Bessie, *In a Walled Garden* (George Bell and Sons, 1881).

Bingham, Colin, *Women: A Modern Miscellany* (Sydney: Currawong Publishing, 1969).

Blake, Robert, *Disraeli* (London: Eyre & Spottiswoode, 1966).

Browning, Robert, Barrett Browning, Elizabeth, *The Brownings' Correspondence* (1984-2015)

——— Vol. 8 (October 1843-May 1844), Philip Kelley and Ronald Hudson [eds.] (Winfield: Wedgestone Press, 1990).

——— Vol. 10 (January 1845-July 1845), Phillip Kelley and Scott Lewis [eds.] (Winfield: Wedgestone Press, 1992).

——— Vol. 13 (May 1846-September 1846), Phillip Kelley and Scott Lewis [eds.] (Winfield: Wedgestone Press, 1995).

Bulwer Lytton, Edward, *Pilgrims of the Rhine* (1834).

——— *Leila: or The Siege of Granada* (London, Longman & Co., 1838).

Bulwer Lytton, Rosina, *Cheveley; or the Man of Honour*, Marie Mulvey Roberts [ed.] (London: Pickering and Chatto, 2005).

——— *The Bubble of the Budget Family*, 3 vols. (London: John Bull, 1840).

——— *The Collected Letters of Rosina Bulwer Lytton*, 3 vols., Marie Mulvey Roberts [ed.] (London: Pickering and Chatto, 2008).

Burke, Edmund, *Reflections on the Revolution in France*, J.C.D. Clark [ed.] (Stanford: Stanford University Press, 2001).

Burns, Robert, *The works of Robert Burns: containing his life*, John Lockhart [ed.] (1835).

Byron, Lord, *The Corsair* (London: John Murray, 1814).

Calhoun, Charles C., *Longfellow: A Rediscovered Life* (Boston: Beacon Press, 2004).

Cardigan and Lancaster, Countess of, *My Recollection* (London, E. Nash, 1909).

Cavendish, Harriet, *Harry-O, The Letters of Lady Harriet Cavendish, 1796–1809*, eds. G. L. Gower and I. Palmer (London: John Murray, 1940).

Chambers, James, *Palmerston, The People's Darling* (London: John Murray, 2005).

Chambers, Montague [ed.], *The Law Journal Reports for the Year 1842: Vol. XX, New Series: Vol. XI* (London: E. B. Ince, 1842).

Chase, Karen, Levenson, Michael, *The Spectacle of Intimacy: A Public Life for the Victorian Family* (Princeton: Princeton University Press, 2009).

Chessell, Anthony *The Life and Times of Abraham Hayward* (London: Lulu Enterprises, 2009).

Chetwynd-Stapleton, Henry, *The Eton School Lists, from 1791 to 1850* (London: E. P. Williams, 1864).

Clairmont, Claire, *The Clairmont Correspondence*, 2 vols. Marion Kingston Stocking [ed.] (Baltimore, MD: The Johns Hopkins University Press, 1995).

Coleridge, S. T., *Specimens of the Table Talk of the Late Samuel Taylor Coleridge*, 2 vols. (London: John Murray, 1835).

——— *The Collected Works of Samuel Taylor Coleridge, Poetical Works 1 (Reading Text)*, J. C. C. Mays [ed.] (Princeton: Princeton University Press, 2001).

Collodi, Carlo, *Le Avventure di Pinocchio* (1883).

Copeland, Edward, *The Silver Fork Novel: Fashionable Fiction in the Age of Reform* (Cambridge: Cambridge University Press, 2012).

Cowper, William *The Solitude Of Alexander Selkirk* (1782).

Craik, Dinah Mulock, *Olive*, 3 vols. (London, 1850).

Crerar, Robert, *The Merchant, Tradesman's and Solicitor's Book of Reference* (London: Basil Steuart, 1831).

- Cromwell, Judith Lissauer, *Dorothea Lieven: A Russian princess in London and Paris, 1785–1857* (Jefferson, NC: McFarland, 2007).
- Darwin, Charles, *The Correspondence of Charles Darwin*, Frederick Burkhardt et al [eds.], Vol. 22, 1874 (Cambridge: Cambridge University Press, 2015).
- Davidoff, Leonere, *Thicker than Water, Siblings and their Relations* (Oxford: Oxford University Press, 2013).
- Dickens, Charles, *Sketches of London Life* (1835).
- *Sketches by Boz*, 2 vols. (London: John Macrone, 1836).
- *Posthumous Papers of the Pickwick Club*, 2 vols. (London: Chapman & Hall, 1837).
- *Dombey and Son*, 3 vols. (London: Bradbury and Evans, 1848).
- *Hard Times*, Graham Law [ed.] (Peterborough: Broadview Press, 1996).
- Disraeli, Benjamin, *Walstein, or a Cure of Melancholy, The Court Magazine and Belle Assemblée* on 1 July 1833 (pp. 3-8).
- *Coningsby*, 3 vols. (London: Henry Colburn, 1844).
- Dowden, Wilfred S., [ed.], *The Journal of Thomas Moore* (Newark: University of Delaware Press, 1983).
- Duff Gordon, Lucie, *Letters from Egypt, 1863-1865* (London, 1865).
- *Last Letters from Egypt* (London, 1875).
- Dufferin and Ava, Marquess of, *Songs, Poems and Verses by Helen Lady Dufferin* (London: John Murray, 1894).
- Dunkley, Henry, *Lord Melbourne* (New York: Harper & Brothers, 1890).
- Eden, Hon. Emily, *Emily Eden's Letters*, Violet Dickinson [ed.] (London: Macmillan, 1919).
- Egerton, Mrs Frederick, *The Countess's Cross* (1868).
- Eliot, George, *Adam Bede* (1859).
- 'Silly novels by Lady Novelists', *The Essays of "George Eliot"*, Nathan Sheppard [ed.] (New York: Funk & Wagnalls, 1883).
- Ellis, S. M., *Wilkie Collins, Le Fanu and Others* (London: Constable & Co, 1931).
- Figes, Orlando, *Crimea* (London: Allen Lane, 2010).
- Flavin, Michael, *Benjamin Disraeli: the Novel as Political Discourse* (Vaughan: Sussex Academic Press, 2005).
- Foot, Paul, *Red Shelley* (London: Bookmarks Publications Limited, 1984).

- Francfort, O. M., *Documents Regarding the Claims of Augustus of Este* (London: H.L. Breonner, 1834).
- Frank, Katherine, *Lucie Duff Gordon* (London: Penguin, 1995).
- Franklin, Caroline, *The Female Romantics: Nineteen-Century Women Novelists and Byronism* (London: Routledge, 2012).
- Gaskell, Elizabeth, *Mary Barton*, Edgar Wright [ed.] (Oxford: Oxford University Press, 1998), Gilroy, Amanda, ‘Christina Rossetti: Sisters, Brothers and the “Other Woman”’, in eds. P. Th. M. G. Liebrechts, Wim Tigges, *Beauty and the Beast* (Amsterdam: Rodopi B.V., 1996).
- Gladstone, William, *The Gladstone Diaries*, vol. 4: 1848-1854, M. R. D. Foot and H. C. G. Matthew [eds.] (Oxford: Clarendon Press, 1974).
- Gleadle, Kathryn and Richardson, Sarah (eds.), *Women in British Politics, 1760-1860* (Houndmills: Macmillan Press Ltd, 2000).
- Goodway, David, *London Chartism* (Cambridge: Cambridge University Press, 1982).
- Gordon, Charlotte, *Romantic Outlaws: The Extraordinary Lives of Mary Wollstonecraft and Mary Shelley* (London: Hutchinson, 2015).
- Gore, Catherine, *Dacre of the South or, the olden Time; A Drama* (1840).
 ——— *The Dowager: Or the New School for Scandal*, 3 vols. (1840).
- Grey, Barberina, *A Family Chronicle: Derived from Notes and Letters Selected by Barbarina, the Honorable Lady Grey*, Gertrude Lyster [ed.] (London: Macmillan, 1908).
- Graham, Thomas John, *Ayurvedic Materia Medica for Domestic Use* (New Delhi: Logos Press, n.d.).
- Graves, Algernon, *The Royal Academy of Arts: a Complete Dictionary of Contributors and their work from its foundation in 1769 to 1904*, Vol. 8 (London: Henry Graves and Co, Ltd, 1906).
- Grey, Charles, *The Early Years of His Royal Highness the Prince Consort, compiled under the direction of Her Majesty, the Queen* (London: Smith, Elder, 1867).
- Griffin, Ben, *The Politics of Gender in Victorian Britain* (Cambridge: Cambridge University Press, 2012).
- Hadley, Elaine, *Melodramatic Tactics: Theatricalized Dissent in the English Marketplace* (Stanford, CA: Stanford University Press, 1995).

- Harrington, Ralph, (1998) *The Neuroses of the Railway: Trains, Travel and Trauma in Britain, c.1850–c.1900* (PhD. thesis, Oxford University, UK).
- Hawthorne, Julian, *Hawthorne and his Circle* (London: Harper & Brothers, 1903).
- Hemans, Felicia, *Records of Women: With Other Poems* (Edinburgh: William Blackwood, 1828).
- Hibbert, Christopher *Queen Victoria, A Personal History* (Cambridge: Da Capo Press, 2000).
- Holcombe, Lee, *Wives and Property* (Toronto: University of Toronto, 1983).
- Homer, *The Odyssey*, trans. Walter Shewring (Oxford: Oxford University Press, 2008).
- Hopkins, A. B., *Elizabeth Gaskell, Her Life and Work* (London: John Lehman, 1952).
- Horne, Richard, *A New Spirit of the Age* (London: Smith, Elder and Co., 1844).
- Holcombe, Lee, *Wives and Property: Reform of the Married Women's Property Law in Nineteenth-Century England* (Toronto: University of Toronto Press, 1983).
- Horne, Richard, *A New Spirit of the Age* (London: Smith, Elder and Co, 1844).
- Hughes, Thomas, *Early Memories for the Children* (London: Thomas Burleigh, 1899).
- Johnson, Claudia L., [ed.], *The Cambridge Companion to Mary Wollstonecraft*, (Cambridge: Cambridge University Press, 2002).
- Jones, Francis, 'Miss Jennings Abroad', *The Carmarthenshire Historian*, Vol.19, Jones, E. Vernon [ed.] (Carmarthen: Carmarthenshire County Council Local History Society, 1982).
- Karlin, Daniel, *The Courtship of Robert Browning and Elizabeth Barrett* (Oxford: Oxford University Press, 1985).
- Kemble, Frances, *Records of a Girlhood*, 3 vols. (New York: Henry Holt & Co., 1879).
- Kilham, John, *Tennyson and the Princess: Reflections of an Age* (London: Athlone Press, 1958).
- Kinglake, William, *Eöthen, or Traces of travel brought home from the East* (1844).
- Kochanski, Halik, *Sir Garnet Wolseley: Victorian Hero* (London: Bloomsbury Publishing, 1999).
- Lamb, Charles, 'The Convalescent', *The Atheneum*, Vol. III: April-October, 1825 (Boston: John Cotton, 1825)
- Le Fanu, Sheridan, *Guy Deverell*, 3 vols. (1865).

- *Wylder's Hand*, 3 vols. (1864).
- Le Fanu, William, *Seventy Years of Irish Life* (London: Edward Arnold, 1893).
- Leighton, Angela, and Reynolds, Margaret [eds.], *Victorian Women Poets, An Anthology*, (Oxford: Blackwell, 1995).
- Longford, Elizabeth, *Wellington: Pillar of State* (London: Weidenfeld & Nicholson, 1972).
- McCormack, W. J. *Sheridan le Fanu* (Stroud: Sutton Publishing, 1997).
- Madden, R.R., *The Literary Life and Correspondence of the Countess of Blessington*, 3 vols. (London: T. C. Newby, 1855).
- Maitland, Sir Frederick Lewis, *Narrative of the surrender of Buonparte and of his residence on board HMS Bellerophon* (London, 1826).
- Malcomson, A. P. W., *The Pursuit of the Heiress: Aristocratic Marriage in Ireland 1740-1840* (Belfast: Ulster Historical Foundation, 2006).
- Marreco, Anne, *The Rebel Countess, The Life and Times of Constance Markievicz* (London: Weidenfeldt and Nicolson, 1967).
- Marshall, Mrs Julian, *The Life and Letters of Mary Wollstonecraft Shelley*, 2 vols. (New York: Haskell House Publishers, Ltd, 1970).
- Martin, Sir Theodore, *Queen Victoria as I Knew Her* (London: Blackwood & Sons, 1908).
- Marx, Karl and Engels, Friedrich, *The Communist Manifesto*, G. S. Jones [ed.] (London: Penguin, 2002), p. 244.
- *Manifest der Kommunistischen Partei* (London: von J. E. Burghard, 1848).
- Masson, Michael, *Vierge et Martyre*, 2 vols. (Paris: 1836).
- Mayhew, Henry, *London Labour and the London poor* (London: Griffin, Bohn and Company, 1861).
- Meredith, George, *Diana of the Crossways*, 3 vols. (London, Chapman & Hall, 1885).
- Meredith, Owen, *Clytemnestra and Other Poems* (1855).
- Milton, John, *Lycidas* (London: Ginn and Heath, 1879).
- Mitchell, Leslie, 'Britain's Reaction to the Revolutions', in Evans and von Strandmann, *Holland House (London: Gerald Duckworth & Co. Ltd, 1980)*.
- *The Revolution in Europe, 1848-1849* (Oxford: Oxford University Press, 2000), pp. 83-98.
- *Lord Melbourne*, (Oxford: Oxford University Press, 1997).

- *Bulwer Lytton, The Rise and Fall of a Victorian Man of Letters* ((London: Hambledon & London, 2003).
- *The Whig World* (London: Hambledon and London, 2005).
- Moore, Tom, *The Poetical Works of the late Thomas Little* (London: J. & T. Carpenter, 1801).
- *The Works of Lord Byron: with his Letters and Journals and his Life*, 17 vols. (London: John Murray, 1830).
- *The Works of Thomas Moore*, 4 vols. (Paris: A and W Galignani, 1832).
- Morris, Charles, *A Manual of Classical Literature* (Chicago: S.S. Griggs and Company, 1888).
- Motley, John Lothrop, *The Correspondence of John Lothrop Motley*, 3 vols. George Curtis [ed.] (London: John Murray, 1889).
- *John Lothrop Motley and his Family, Further Letters and Records*, Susan and Herbert St John Mildmay [eds.] (London: John Lane, 1910).
- Munsell, F. Darrell, *The Unfortunate Duke* (Columbia: University of Missouri Press, 1985).
- Munster, Countess of, *My Memories and Miscellanies* (London: Eveleigh Nash, 1904).
- Murphy Derrick, *et al, Britain, 1783-1918* (London: Collins, 2003).
- Murphy, Arthur, *The Upholsterer* (1758), *The Works of Arthur Murphy, Esq* (London: T. Cadell, 1782).
- Murray, Elizabeth Alicia, *Robert Chetwynd's Confession*, 3 vols. (London: John Murray, 1868).
- Nadel-Klein, Jane, 'Occidentalism as a Cottage Industry: Representing the Autochthonous Other in British and Irish Village Studies', *Occidentalism: Images of the West*, James G. Carrier [ed.] (Oxford: Clarendon Press, 1995), pp. 109-34.
- Newbould, Ian D. C., 'Stanley, Edward John, second Baron Stanley of Alderley and first Baron Eddisbury (1802-1869)'.
- Norton, Brinsley, *Pinocchi* (London: John W. Parker and Son, 1856).
- *The Turkish Flag* (London: Reynell and Wright, 1854).
- Nugent, Emily, *A Narrative of the Case of the Marchioness of Westmeath* (London: James Ridgeway, 1857).
- Percy, Thomas [ed.], *Reliques of Ancient English Poetry: Consisting of Old Heroic Ballads, Songs and Other Pieces*, (Philadelphia: F. Bell, 1855).

- Piozzi, Hester, *The Piozzi Letters: 1811-1816*, Edward A. Bloom and Lillian D. Bloom [eds.] (Plainsboro: University of Delaware Press, 1999).
- Poovey, Mary *Uneven Developments* (Chicago: University of Chicago, 1988).
- Pope-Hennessy, James, *Monckton Milnes, The Years of Promise*, (Constable: London 1949).
- *The Flight of Youth* (London: Constable & Company, 1952).
- Preston, Antony and Major John, *Send a Gunboat! 150 Years of the British Gunboat* (London: Conway, 2007).
- Prince, Mary, *The History Of Mary Prince, A West Indian Slave* (London: Thomas Pringle, 1831).
- Reynolds, K. D., *Aristocratic Women and Political Society* (Oxford: Oxford University Press, 1998).
- Ridley, Jane, *The Young Disraeli, 1804-1846* (London: Sinclair–Stevenson, 1995).
- Ritchie, Anne Thackeray, *Thackeray's Daughter, Some Recollections of Anne Thackeray Ritchie*, Hester Thackeray Fuller and Violet Hammersley [eds.] (Dublin: Euphorion Books, 1951).
- Robinson, H. Crabb, *Books and Their Writers*, Edith J. Morley [ed.] (London: J. M. Dent & Sons, 1938).
- Robinson, William Etty: *The Life and Art* (Jefferson: McFarland & Company, 2007).
- Rowe, G. R., *Practical Treatise on indigestion & nervous disorders* (1820).
- Scott, Sir Walter *The Poetical Works of Walter Scott* (Edinburgh: Robert Caddell, 1841).
- Sedgwick, Theodore, *Public and Private Economy*, 2 vols. (New York: Harpers & Brothers, 1838).
- Seneca, *Heracles Furens*, John G. Fitch [ed.] (Ithaca: Cornell University Press, 1987).
- Seymour, Miranda, *Mary Shelley* (London: John Murray, 2000).
- Shannon, Richard, *Gladstone, 1809-65* (London: Methuen, 1982).
- *Gladstone, Heroic Minister* (London: Allen Lane, 1999).
- Shelley, P. B., *The Witch of Atlas* (1824).
- *The Masque of Anarchy*, (London: Edward Moxon, 1832).
- *The Poetical Works of Percy Bysshe Shelley*, Mary Shelley [ed.], 4 vols. (London: Edward Moxon, 1839).
- Sheridan, Caroline, *Carwell* (London: Henry Colburn and Richard Bentley, 1830).
- *Aims and Ends and Oonagh Lynch* (London: Edward Bull, 1833).

- Shirley, James, *Dramatic Works and Poems*, 6 vols. eds. William Gifford and Alexander Dyce (London: John Murray, 1833).
- Silmon-Monerri, Joe A. A., *The Secret Life of the Earl St. Maur* (Bloomington: Trafford Publishing, 2010).
- Smiles, Samuel, *A Publisher and his Friends* (Cambridge: Cambridge University Press, 2014).
- Souvestre, Émile, (Paris: Marchant, *Riche et Pauvre*, 1837).
- Stapleton, Harriet, *The Pastor of Silverdale* (London: William Macintosh, 1866).
- Steinbach, Susie, *Women in England, 1760-1914* (London: Phoenix, 2005).
- Sterne, Laurence, *A Sentimental Journey Through France and Italy* (1768).
- Stirling, William, *Annals of the Artists of Spain*, 3 vols. (London: John Oliver, 1848).
- *Songs of the Holy Land* (Edinburgh: privately printed, 1846).
- *The Chief Victories of Charles V* (Edinburgh: privately printed, 1870).
- *Don John of Austria* (London: Longman, 1883).
- Stone, Lawrence *Road to Divorce* (Oxford: Oxford University Press, 1990).
- Strachey, Lytton, *Queen Victoria* (London: I. B. Tauris, 2012).
- Sumner, Charles, *Memoirs and Letters of Charles Sumner*, 3 vols. Edward L. Pierce [ed.] (London, Sampson Low, 1878).
- Sunstein, Emily W., *Romance and Reality* (Baltimore: John Hopkins Press, 1989).
- Temple, Neville and Trevor, Edward, *Tannhauser, or The Battle of the Bards* (London: Chapman & Hall, 1861).
- Sutherland, John, *The Longman Companion to Victorian Fiction* (London: Longman, 1988).
- Tennyson, Emily *Emily Tennyson's Journal*, James O. Hoge [ed.] (Charlottesville: University Press of Virginia, 1981).
- Thynne, Harriet Frances, *Colonel Fortescue's Daughters*, 3 vols. (London: Hurst & Blackett, 1868).
- Todd, Janet, *Death and the Maidens: Fanny Wollstonecraft and the Shelley Circle* (London: Profile Books, 2007).
- Trelawny, Edward, *Records of Shelley, Byron and the Author*, 2 vols. (London: Basil, Montagu, Pickering, 1878).
- *Recollections of the Last Days of Shelley and Byron* (Boston: Tichnor and Fields, 1858).
- Trimmer, Sarah, *History of the Robins* (1821).

Trollope, Anthony, *The Letters of Anthony Trollope*, 2 vols. John Hall [ed.] (Stanford: Stanford University Press, 1983).

Stapleton, Harriet, *The Pastor of Silverdale* (London: William Macintosh, 1866).

Turner, E. S., *What the Butler Saw, Two Hundred and Fifty Years of the Servant Problem* (London: Penguin, 2001).

Victoria, Queen, *Leaves from the Journal of Our Life in the Highlands* (London: Smith, Elder and Company, 1868).

Vigne, Randolph, *Thomas Pringle: South African Pioneer, Poet and Abolitionist* (Woodbridge: Boydell & Brewer, 2012).

Wagner, Richard, *My Life*, 2 vols. (Rockville Press, Wildside Press, 2010).

Walker, John, *Yorkshire Pedigrees* (Yorkshire: J. Whitehead and Son Ltd, 1942).

Ward, Wilfred, *Aubrey de Vere, A Memoir* (London: Longman & Do., 1904), p. 99.

The Hunchback by James Sheridan Knowles (1756-1840).

Watt, Julie, *Poisoned Lives: The Regency Poet Letitia Elizabeth Landon (L.E.L.) and British Gold Coast Administrator George Maclean* (Eastbourne: Sussex Academic Press, 2010).

Welch, R. Courtenay, *The Harrow School Register, 1800-1911* (London: Longman, Green & Co, 1911).

Wilson, A. N. *The Victorians* (London: Hutchinson, 2002).

Wiltshire, Irene [ed.], *Letters of Mrs Gaskell's Daughters* (Perith: Humanities-E Books, 2012).

Wollenberg, Susan, *Schubert's Fingerprints: Studies in the Instrumental Works* (Farnham: Ashgate Publishing, Ltd, 2011).

Woolford, John and Karlin, Daniel, *Browning* (London: Routledge, 2014).

Ziegler, Philip, *Lord Melbourne* (London: Fontana, 1978).

APPENDIX 1

BIOGRAPHICAL INDEX OF RECIPIENTS

(The number of letters sent to each recipient in terms of the total extant correspondence appears in brackets following the name and brief description of each. The index is intended for reference, so some information may be repeated.)

Babbage, Charles (1791-1871), mathematician and computer pioneer (6)

Norton wrote to Charles Babbage during the 1830s and 1840s, when he was already established in scientific circles and involved in developing his automatic calculating engine. With the exception of the letter included in this edition, in which she asked him to support Lord Russell's by-election campaign, the correspondence mainly consists of invitations and references to projected or missed meetings. On one occasion, she thanked him for 'your book', noting that it 'will require my best attention',¹ perhaps implying that he had sent her one of his scientific or mathematical works.

Bentley, Richard (1794-1871), printer and publisher (3)

It seems likely that Norton corresponded with Richard Bentley intermittently throughout her adult life, as there are letters written to him from the early 1830s until 1865. The first letter is included and discussed in this edition. The last letter concerns a review she anticipated writing of *Uncle Silas* (1864) by Sheridan Le Fanu, who was a distant cousin. In addition to approaching Bentley to publish one of her own works, Norton also hoped that he would publish her mother's novel, *Aims and Ends* (published in 1833 by Edward Bull), as 'during the 1830s and 1840s Bentley was at the top of his form', offering 'good value and well-produced books'.²

Bohn, Henry George (1796-1884), translator and publisher (1)

Norton appears to have become acquainted with Bohn in the early 1870s as the letter to him included in this edition, in addition to two further references in the correspondence, are from this period. Although Bohn had by this time sold his publishing business, she valued his advice as someone with a lifetime of experience, whom she could trust to publish her books, for which there was then still a market. In addition, they exchanged books and opinions on literary matters.

¹ CN to Charles Babbage, 5 June 1837, BL, Add MS, 37201, f.256.

² *ODNB*.

Brougham, Henry, first Baron Brougham and Vaux (1778-1868), politician and Lord Chancellor (9)

Born into fairly modest circumstances, Brougham joined the radical Clapham sect in 1804 and became an MP in 1810. On his appointment as Lord Chancellor in Lord Grey's Whig government in 1830, he entered the House of Lords, where he was instrumental to the passing of the Great Reform Act. Acting on what appears to have been the advice of Norton and Lord Lyndhurst,³ Melbourne put the great seal in commission when he formed his second administration in April 1835, thereby condemning Brougham to the political wilderness. Brougham took Norton's intervention very badly: it is possible to trace his hostility or neutrality to the Infant Custody Bill and Norton's later attempts to secure the property and income of separated women, reforms for which he should have been a natural supporter, to his suspicion that Caroline had turned Melbourne against him. The letters to Brougham included in the edition illustrate the importance she attached to regaining and then securing his support.

Browning, Robert (1812-1889), poet (1)

The letter to Robert Browning included in this edition is the only reference to him or to his work in the existing correspondence. There is no evidence of any correspondence between Caroline Norton and Elizabeth Barrett Browning. Norton wrote to Richard Hengist Horne in March 1844, asking if she could write to Elizabeth Barrett, but his response is unknown. Horne had previously asked both Barrett and Browning to suggest epigraphs for his forthcoming series of biographical sketches, *The New Spirit of the Age* (1844), inspired by William Hazlitt's *The Spirit of the Age* (1825). In the former work, Norton and Elizabeth Barrett were to be discussed comparatively, or 'fastened up in a gold cage together'⁴ as Barrett put it. Extracts from Shelley were recommended by Browning to introduce four other female writers: Norton, Harriet Martineau, Mary Shelley and Elizabeth Barrett.⁵ Eventually, the lines suggested as an epigraph for a section on Norton were adopted by Horne to introduce

³ CN to Lord Melbourne [circa April 1835], BC, Maggs, 10.23.63.

⁴ Elizabeth Barrett to Mary Russell Mitford, 13 March 1843, Philip Kelley and Ronald Hudson, *The Brownings' Correspondence* (Winfield: Wedgestone Press, 1990), Vol. 8, p. 254.

⁵ *Brownings' Correspondence*, Vol 8, pp. 203-5.

the chapter on both Norton and Elizabeth Barrett.⁶ Interestingly, Norton shared what Harold Bloom believes to have been ‘Browning’s sense of inferiority to the Romantic poets generally and Shelley in particular’.⁷ To this Romantic generation she would have added Tennyson, who she described as ‘my superior’,⁸ although there is no equivalent in her letters to what Daniel Karlin and John Woodford have identified as ‘Browning’s sense of having failed in the poetic mission he had undertaken’.⁹ Browning took an interest in her poetry and in a letter written to Elizabeth Barrett in April 1845, which Karlin suggests ‘sends a clear signal of anxiety about being neglected’,¹⁰ criticised *The Child of the Islands* (1845) as hastily-written and, whatever its philanthropic aspirations, politically complacent.¹¹ Browning’s disapproval of the poem may have contributed to the achievement of his objective of eliciting a response from Barrett, as in her reply to him two days later she drily praised Norton’s musical, rather than her literary, abilities (with reference to the scene in *Hamlet* where Guildenstern is asked to play a recorder): ‘But Mrs Norton discourses excellent music.’¹² However, whatever his reservations about her talent as a poet, Browning believed Norton to be the largely innocent victim of entirely inaccurate gossip. When Barrett informed him, in tones of the highest confidentiality, that the artist Benjamin Robert Haydon, who at one time had been infatuated with Caroline, had told her ‘in so many words that M.^{rs} Norton had made advances towards him – – & that his children in sympathy towards their mother, had dashed into atoms the bust of the poetess as it stood in the painting room,’¹³ Browning took a sceptical approach

⁶ P. B. Shelley, ‘Music’ (*Posthumous Poems*, 1824), ll. 19-22; Richard Horne, *A New Spirit of the Age* (London: Smith, Elder and Co, 1844), Vol. 2, p. 130.

⁷ John Woolford and Daniel Karlin, *Browning* (London: Routledge, 2014), p. 172.

⁸ See Letter 135, Vol. 2, p. 386.

⁹ Woolford and Karlin, *Browning*, p. 172.

¹⁰ Daniel Karlin, *The Courtship of Robert Browning and Elizabeth Barrett* (Oxford: Oxford University Press, 1985), p. 196.

¹¹ Robert Browning to Elizabeth Barrett, 15 April 1845, Phillip Kelley and Scott Lewis [eds.], *The Brownings’ Correspondence* (1992), Vol. 10, p. 48: ‘And Mrs Norton has gone and book-made at a great rate about the Prince of Wales, pleasantly putting off till his time all that used of old to be put off till his mother’s time’. In *The Child of the Islands*, the Prince of Wales, then aged three, is taken on a tour of Britain, during which the social inequalities of his future subjects are pointed out of him. Browning is suggesting that the poem implies the postponement of any real prospect of reform until the Prince of Wales becomes King.

¹² Elizabeth Barrett to Robert Browning, 17 April 1845, *The Brownings’ Correspondence*, Vol. 10, p. 170; Shakespeare, *Hamlet*, Act 3, Scene 3, l. 347: ‘Give it breath with your mouth, & it will discourse most eloquent musique’. Barrett may be responding to Browning’s implication that *A Child of the Islands* advocates postponing social reform by referencing a play that also has theme of procrastination.

¹³ Phillip Kelley and Scott Lewis [eds.], Elizabeth Barrett to Robert Browning, 6 July 1846, *The Brownings’ Correspondence*, Vol. 13, p. 125.

towards Haydon, who had committed suicide two weeks earlier: ‘For the bust-story, – the telling *that*, if it were true, is nearly as bad as inventing it. That poor woman is the hack-block of a certain class of redoubtable braggarts – there are such stories by the *dozen* in circulation ... All may have been misconception ... “advances” – to induce one more painter to introduce her face in his works.’¹⁴ He was aware of Norton’s overspending, commenting to his wife shortly after their marriage on the alleged cost of a gown (costing five shillings and sixpence) that the former had recently purchased.¹⁵ Kelley and Lewis suggest that ‘although Caroline Norton was frequently mentioned by the Brownings, especially EBB, they had little contact with her’¹⁶ and there is currently no record of an actual meeting between the two women. However, the context of the references in the *Browning Correspondence* suggest that they may have become acquainted in 1854-5 in Florence, where her son Brinsley, a frequent visitor to the Casa Guidi, had been given rooms by Frederick Tennyson in the Villa Torrigiani, where Isa Blagden, a protégé of Barrett, was also staying. Caroline stayed at the Villa during the winter of 1854-5. However, Caroline may have been frustrated when trying to make contact with the Brownings a year later in Paris. Hearing that she spoke of ‘of finding us out & calling on us’, they opted to remain ‘*perdue*¹⁷ for the present’.

Campbell, John, second Marquess of Breadalbane (1796-1862), politician and courtier (2)

The Marquess of Breadalbane was Lord Chamberlain from 1848 to 1852 and 1853 to 1858 and was a friend of the Queen, who stayed at his castle at Taymouth (as did Caroline) and was much taken by his appearance in full Highland dress. He was kind to Caroline, in May 1851 sending her a season ticket to the Crystal Palace exhibition, to which she responded with a copy of *Stuart of Dunleath*. He proved a useful conduit to the Queen, both in terms of influencing how Caroline was received at Court functions and, four years later, as a go-between, carrying her gifts (two quotations from a guide to France about Napoleon III) to the Queen, in the hope of engaging the monarch’s attention in advance of Caroline’s pamphlet, *Letter to the Queen*, which she was then completing.

¹⁴ Robert Browning to Elizabeth Barrett, 7 July 1846, *ibid*, p. 133.

¹⁵ Elizabeth Barrett Browning to Robert Browning, 5 August 1846, *ibid*, p. 229.

¹⁶ *The Brownings’ Correspondence* (1995), Vol. 13, p. 312.

¹⁷ ‘Hidden’ (*French*).

Charteris, Lady Anne (1823-96), philanthropist (5)

Lady Anne Anson, second daughter of the 1st Earl of Lichfield, married Francis Charteris, (later 10th earl of Wemyss), a politician, in 1843. They had six sons and three daughters. She became Lady Wemyss on the death of the 9th Earl of Wemyss in 1883. Norton and Lady Charteris were involved in publicising the Canterbury Association, founded on 27 March 1848 by Edward Wakefield and John Godley with the objective of establishing a colony in New Zealand sponsored by the Church of England. The Canterbury Association Committee included Francis Charteris and Sidney Herbert, who may have introduced Norton to Charteris.

Cowell, Augusta, (1801-1870), musician and composer (31)

Augusta Cowell collaborated with Norton on comic operas, such as *The Gypsy Father* and *The Rose of the Village* and on songs and ballads. Cowell also wrote music for Helen Dufferin and continued to write with both sisters until the 1860s. The youngest daughter of John B. Cowell, Augusta was from a middle-class background and lived with her mother and banker brother near Hyde Park until 9 August 1849, when she married the Rev. Hon. Paul Irby (1784-1865), the rector of Cottesbroke in Northamptonshire. The third son of Lord Boston, Irby had been twice widowed and was already the father of eleven children, of whom those by his second wife were ten and eight years old at the time of his marriage to Augusta.

Delane, John Thadeus (1817-1879), newspaper editor (41; in addition, 36 letters were addressed to ‘the editor of *The Times*’ during May 1841-77, when Delane was editor).

The great majority of Norton’s surviving personal letters to Delane were written during the 1860s and concern articles and letters she had written for and to *The Times*, such as the references to the reviews of her cousin Sheridan Le Fanu’s novels *Uncle Silas* (Letter 120) and *Guy Deverell* (1865) (Letter 123) by the same author. Norton was alleged, both in December 1845, when the story first emerged, and subsequently, most famously by George Meredith in *Diana of the Crossways*, of selling the story of Peel’s change of policy over Corn Law Repeal to Delane. It has been argued that she was passing on information confided to her by Sidney Herbert, though it seems far more likely that the report was leaked by another source.

Dickens, Charles (1812-1870), novelist (1)

The research for this thesis has identified a letter, previously thought to be sent by Norton in 1837 to an unknown recipient, as to Dickens. She also wrote three letters, between 1842 and 1850, to Dickens's wife, Catherine. Clearly written at an early stage in the friendship, the letter to Dickens reveals the very high regard in which Norton held the novelist. Given that he was friends with her younger brother, Charles, and later took an interest in the marriage of her second son, Brinsley, it seems likely that Norton and Dickens exchanged letters more than once. There are a further fourteen references to him in her correspondence.

Disraeli, Benjamin, Earl of Beaconsfield (1804-1881), prime minister and novelist (8)

The majority of Norton's letters to Disraeli were written during the 1830s and concern his novels and political aspirations. She correctly predicted that he would become a Tory (Letter 11), discussed his story *Walstein, or a Cure for Melancholy* (1833), which she published in her magazine, *The Court Magazine and Belle Assemblée* (Letter 12) and advised him on which party to represent (Letter 13). She was certainly unsympathetic to his Tory politics after he was elected as a Conservative MP in 1837. However, her later letters to him are warm in tone. In a letter of March 1874, written shortly after he became Prime Minister, she refers to him familiarly as 'Mr Curry'¹⁸ and complains of the ballot system by which women were selected to watch the House of Commons proceedings, as she had thought that MPs had the right to invite female friends to attend.

Disraeli, Mary Anne, Viscountess Beaconsfield (1792-1872), political wife (6)

Five of the six letters to Mary Anne Disraeli were written in the mid-1840s and strongly indicate that Norton was in regular contact with the Disraelis and that they attended society events together (as she had done with Disraeli when he was single). She responded to Mary Anne's invitation to meet Lord John Manners and George Smythe (two prominent members of the Young England movement)¹⁹, or to see a French play and (on two occasions, one of which features in the letter included in this edition) the opera. She thanked Mary Anne for giving a 'violet plant' to her son Fletcher. A letter written in 1872, requesting that she bring her grandson to the

¹⁸ CN to Benjamin Disraeli, 19 March 1874. PRONI, D1071/F/E/2/11.

¹⁹ CN to Mary Anne Disraeli, 5 June 1844, BOD, Dep 233-2-134-5.

Disraeli's house at 93 Park Lane, so that he could he would have a good view for a procession, indicates that the friendship was maintained.

Ellice, Edward (1783-1863), merchant and politician (37)

A brother-in-law of the second Earl Grey, Ellice became an MP in 1818, was included in Grey's Whig government and joined the cabinet in 1834. The surviving letters to him were all written between the mid-1830s and the late 1850s. During this period he was unfailingly supportive of Norton, who found him a trustworthy confidante. She habitually referred to him by his nick-name of 'the (Old) bear, which was appropriate from his connection with the fur trade of the Canadian north-west and also fitted certain aspects of his character',²⁰ in particular his imposing stature and commanding presence.

Esterházy de Galántha, Prince Pál Antal (1786-1866), Hungarian prince, diplomat and politician (4)

As head of the Esterházy family, Prince Paul was enormously wealthy. In 1848 he owned four enormous palaces, thirty four castles, forty towns and one hundred and thirty villages. Norton became acquainted with him in the late 1820s or early 1830s, when he was Austrian ambassador to London (1815-42) and his wife Theresa was one of the Lady Patronesses of Almack's. After meeting him again in Vienna in the 1850s, she requested his 'kind recollection of one you knew, when you were a young man in a great position in England. & I was an English girl with at least my future full of hope, & my present full of the little womanly triumphs of that careless age'.²¹ Her feelings towards him appear to have been mixed. After his death, in a letter to Robert Bulwer-Lytton included in this edition, she described him as both 'good natured' and as 'the Sinner who goes by the name of a saint'. As discussed in this thesis, in one of her letters to him²² she alludes to Sidney Herbert, when he was still single, as having been by mutual consent her future intended husband in the event of George Norton's death.

Fitzmaurice, Charlotte Countess of Orkney (1807-83) (1)

²⁰ ODNB.

²¹ CN to Count Paul Esterházy, *circa* 15 July 1856, NAH, P 136 (Esterházy cs. lvt. - E. Pál hg. Nagykövet irata) 4. D. 8. tétel, ff. 567-70.

²² See n7.

While she was writing her pamphlet on *The Natural Claim of the Mother*, Norton contacted Charlotte Fitzmaurice to request further details concerning her mother-in-law, the Countess of Kirkwall, who had lost access to her children in 1809 and subsequently divorced her husband, John Fitzmaurice, Viscount Kirkwall. Norton does not appear to have known Charlotte, who had married Thomas FitzMaurice, 5th Earl of Orkney, in 1826, in any other capacity, although elsewhere in her letters she does briefly discuss the Earl of Orkney's second cousin, Henry Petty-FitzMaurice, and his father, the 3rd Marquess of Lansdowne (a son of the former Prime Minister, Lord Shelburne), with both of whom she appears to have been on more familiar terms.

Fox, Elizabeth Vassall, Lady Holland (1771-1845), political and literary hostess (14)

Elizabeth Vassall was first married at the age of fifteen to Sir Godfrey Webster, by whom she had three surviving children. In 1794, while in Naples with her husband, she met Henry Fox, the third Baron Holland, for whom she left her husband. He divorced her in 1797 and she married Fox, by whom she had already had a child and by whom she would have four more surviving children (including the Hon. Mary Fox). Already known to be a woman of domineering temperament, her notoriety worsened when it was discovered that she had made up the story of the illness, death and burial of one of her children by Webster. The child was returned to him in 1799. Lady Holland held an appeal for Norton, whose parents were guests at Holland House and had children of comparative ages to the Holland offspring. The letter to Lady Holland included in this edition, written when Norton was recovering from a miscarriage and a nervous breakdown, indicates the former's supportive qualities.

Fox Henry Richard, 3rd Baron Holland (1773-1840), politician and man of letters (6)

Henry Fox met Elizabeth Vassall, the wife of Sir Godfrey Webster, in Naples in 1794. They were married in 1797, immediately after Webster divorced Elizabeth, and had six children, five of whom were legitimate and four of whom survived infancy. Fox became one of the leading Whig speakers in the Lords, adopting a radical position on several issues, such as Catholic Emancipation. He became Privy Seal in the Ministry of all the Talents but, following the government's fall in 1807, retained his Whig convictions, opposing the restoration of the Bourbons to France in 1814 and the execution of Marshal Ney in 1815, and was out of office for twenty-three years. His

twenty-year campaign for Catholic Emancipation was vindicated in 1828 when Russell's motion for repeal overcame government opposition, but in 1830 he was prevented by illness from taking the position offered to him of Foreign Secretary in Grey's administration. Norton's early literary letters to him gave way in the late 1830s to appeals for his counsel and support regarding the Infant Custody Campaign, such as that in the letter to him included in this edition, which was written to accompany the gift of some books and her most recent pamphlet.

Fox, Mary Augusta, Lady Holland (1812-1889), linguist (21)

The majority of Norton's letters to Mary Fox were written during the 1850s, mainly in France and Italy, where both women lived for extensive periods. A daughter of the 7th Earl of Coventry, the future 4th Lady Holland married Henry Fox (1802-1859) in 1833. Fox inherited his father's baronetcy in 1840. His well-connected parents had ensured that he had early contact with the European social elite. He knew Lord Byron and had affairs with both Lady Caroline Lamb and Countess Theresa Guiccioli, both of whom were former mistresses of Byron. Fox chose a diplomatic career over a political one and, despite his 'absenteeism and ineptitude', secured a series of desirable appointments through his friends in British politics and 'a wide network of international contacts including Metternich, Talleyrand, Lieven, Esterházy, and Jerome Bonaparte'.²³ The couple had no surviving children but adopted a daughter, Marie Fox, who in 1872 married Aloise Prinz von Liechtenstein. Due to Henry Fox's career, he and his wife lived mainly in Europe and as a result, Mary Fox became 'a notable linguist'.²⁴ Norton's correspondence with her indicates that they shared not only a wide circle of acquaintances but also a secure and lasting friendship, as a comment in a letter in 1873 by Norton to Mary Fox in 1873 demonstrates: 'People are floated from each other in this world, like sea-weed, swirling round little jutting out rocks into separate creeks – one scarce knows how. But I have never lost the interest I felt in you & your destiny – or the memory of more familiar days; – nor ever wavered in the conviction that even foes – (if you have foes) – must admit the patient & enduring generosity you have shown in many a strange hard hour of your life.'²⁵

Fox, the Hon. Mary Elizabeth (1806-1891), philanthropist (3)

²³ *ODNB*.

²⁴ *Ibid*.

²⁵ CN to Mary Fox, 4th Lady Holland, 10 June 1873, BL, Add MS 52126, f.167.

Mary Fox was the only daughter of the 3rd Baron and Lady Elizabeth Holland. She was a bridesmaid at the Nortons' wedding and became Baroness Lilford of Lilford on her marriage in 1830 to Thomas Powys, 3rd Baron Lilford of Lilford, although Caroline continued to refer to her by her maiden name until the 1870s. She became unwittingly involved in the disagreement between the Nortons on 29 March 1836, which led to the separation the following day. George had objected to his wife's attending dinner with Lady Mary Fox, to which he had not been invited, complaining 'that it was the last dinner he would permit to accept singly, & that he thought it very bad taste in Mary Fox encouraging such a thing, as my going out without him'.²⁶ She stood by Caroline during the very troubled period after the 1836 trial: 'Mary Fox came here to see me, but God knows just now I scarcely care what becomes of me – or who stands by – or forsakes me!'²⁷

Friswell, James Hain (1825-1878), essayist and novelist (14)

James Friswell had a long career as a journalist and editor and was involved in a wide variety of social concerns, which included assisting in ragged schools and helping the poor and deprived. While visiting Norton's brother's house at Frampton Court in December 1869, he ruptured a blood-vessel and was henceforth an invalid, although he continued to regularly publish novels and essays. Norton refers to his 'delicate health' in an earlier letter, but most of the correspondence was written in the 1870s. She took a keen interest in his literary work and was impressed by his continued prolific literary output.

Gaskell, Elizabeth (1810-1865), novelist and short-story writer (3)

Although written over three months in early 1859, the tone of the letters to Elizabeth Gaskell, two of which refer to recent literary events (the Crystal Palace poetry prize and Tennyson's readings of the latest instalment of *Idylls of the King*), suggest a much longer friendship. Gaskell included a stanza from *Child of the Islands* as one of the epigraphs in *Mary Barton* (1848) and it has been argued that that Norton's novel *Lost and Saved* (1851) was inspired by Gaskell's *Ruth* (1853).²⁸ Writing in September 1854 to her daughter Meta, Gaskell sent 'kind regards to Mrs Norton'²⁹ and in a letter

²⁶ CN to Edward Ellice, 20 April 1836, NLS, MS 15037 ff. 105-8.

²⁷ *Ibid*, 6 July 1836, NLS, MS 15037 ff. 93-4. This is the more likely allusion, though it is possible that CN is referring to Lady Mary Augusta Fox.

²⁸ A. B. Hopkins, *Elizabeth Gaskell, Her Life and Work* (London: John Lehman, 1952), p. 132.

²⁹ Elizabeth Gaskell, *Mary Barton*, Edgar Wright [ed.] (Oxford: Oxford University Press, 1998), p. 482.

written in 1868, three years after the novelist's death, Norton wrote to John Delane, complaining about a writer that he wanted her to review: 'no word in the Times, – nor all your comparison & love for 'Woman' (which I am shocked to perceive she chiefly relies on), – will make a M^{rs} Gaskell [...] of the lady who wrote that appeal' (Letter 131).

Gladstone, William Ewart (1809-1898), prime minister and author (9)

All Norton's letters to Gladstone were written between the mid-1850s and the late 1860s. Another four letters were written to his wife, Catherine, and there are in addition 43 further references to Gladstone in the letters. The friendship appears to have been initiated in 1854 when Norton sent him her pamphlet, *English Laws for Women in the Nineteenth Century* (Letter 95). She then sent follow-up letters, thanking him for having read the pamphlet and attempting to enlist his support in her campaign to protect the income of separated women and discussing complex divorce reform issues (Letter 96). Although she also sent him her later pamphlet, *A Plain Letter to the Lord Chancellor on the Infant Custody Bill*, he vigorously opposed the Divorce and Matrimonial Causes Bill throughout the hot summer of 1857. In her later letters she revealed a more personal tone, sharing details of her life with her son Brinsley's family (Letter 108), asking if she could introduce him to John Lothrop Motley (Letter 109) and suggesting that William Stirling show Gladstone around his house at Keir on a projected visit (Letter 109). In 1865 she correctly anticipated that Gladstone would assume sole leadership of the Liberal Party and later made it clear that she hoped he would win the 1868 general election (Letter 132).

Gordon, Alexander Duff, 3rd Baronet (1811-1872), Treasury official (10)

Alexander Duff Gordon's father, Sir William Duff Gordon, 'inherited the baronetcy and sherry cellars of his maternal uncle, Sir James Duff,' who on his death in 1815 'left large debts which were inherited initially by Sir William and then, after he died in 1823, by his wife',³⁰ Caroline. She travelled to Spain with her four children to sell the sherry business and made enough to support herself and her two daughters, but Alexander and his younger brother, Cosmo, had to earn their own living. Alexander became a junior clerk in the Treasury and as he was 'handsome, charming, witty and intelligent',³¹ he was welcomed into society, despite his humble position in life. Norton

³⁰ Katherine Frank, *Lucie Duff Gordon* (London: Penguin, 1995), pp. 100-101.

³¹ *Ibid*, p. 100.

was dancing with Alexander at a grand ball held at Landsdowne House in early 1839, when his future wife, Lucie Austin, first set eyes on him. After their marriage in May 1840, the Duff Gordons' house developed into a salon attracting the luminaries of London society. Duff Gordon became a senior clerk at the Treasury in 1854 and a Commissioner of Inland Revenue in 1856. After his wife's departure for Africa (see entry for Lucie Duff Gordon), Norton remained friends with Alexander Duff Gordon, who she privately referred to as 'Semi-hub'.

Gordon, Lucie Duff [*née* Austin], (1821-1869), travel writer and translator (10)

Lucie Austin was the only child of John Austin, a legal philosopher, and Sarah Taylor Austin, a translator and writer. As a child, Lucie knew John Stuart Mill, Jeremy Bentham, Thomas Carlyle and John and Harriet Taylor. The Austins had three children and also adopted Hassan al-Bakkeet, a boy from the Sudan. Like Norton's father, Lucie contracted tuberculosis and went to live in South Africa in the hope that the warm climate would improve her condition. In 1862 she sailed for Egypt, where she wrote letters about village life critical of westernisation, which were later published. She died in Cairo in July 1869. Norton subsequently wrote a profile of her for *Macmillan's Magazine*, in which she discusses *Letters from Egypt*: 'They describe a life utterly new to us, and a people very imperfectly known or studied by European travellers; a people who have hitherto had but slender hold on our sympathies. Is it too much to expect that the popular letters of this gifted woman may do more towards wakening that sympathy and increasing interest than even the visits of a Viceroy?'³²

Gore, Catherine (1798-1861), novelist and playwright (10). A prolific author of over 70 works, Catherine Gore continued to write when partially and even entirely blind. In 1823 she published her first novel and married Charles Gore, a Lieutenant in the Life Guards. The majority of Norton's extant letters to Gore were written between the mid-1830s and mid-1840s, a period during which the latter's contented domestic situation must have presented a happy contrast to Norton's troubled circumstances. She took a great interest in Gore's daughter, Cecily, particularly when Cecily married the much older bankrupt and spendthrift, Lord Edward Thynne, who Norton had herself known for at least two decades. She was impressed by Gore's prolific completion of novels, which compared favourably with her own interrupted novel-

³² CN, 'Lady Duff Gordon and her Works', *Macmillan's Magazine*, September 1869, pp. 460.

writing career: during the fifteen years of the extant correspondence she published only one novel, *Stuart of Dunleath*, while Gore produced forty fictional works.

Hall, Samuel Carter (1800-1889), journal editor and writer (2)

An enormously energetic journalist, Hall edited or contributed to a wide variety of publications over a sixty-year period, often in collaboration with his wife, Anna Maria Fielding (1800-1881), who also wrote novels, plays, reminiscences, children's tales 'and an endless stream of homiletic essays, tracts, sketches, and stories'.³³ Widely satirised for 'his oily and voluble sanctimoniousness',³⁴ he 'is generally regarded as the model for Pecksniff in *Martin Chuzzlewit*'.³⁵ Norton's letters to Hall concern two of the publications he edited, the *New Monthly Magazine*, to which she had submitted a short story that he had failed to either accept or return (Letters 6 and 8), and *The Art Journal*, an inspection copy of which was sent to her house in 1855, in the hope that she would become a subscriber.

Hay [née Sheridan], Helen Selina, Countess of (1807-1867), author, song writer and Caroline's elder sister (50)

Helen collaborated with Caroline in some of her juvenile works, but the sisters were separated in 1814 when Helen accompanied her parents to Cape Town. On her father's death in 1817 she returned to England with her mother and in 1825 married Price Blackwood, heir to the Earl of Dufferin, by whom she had a son, Frederick. She collaborated with Caroline in a series of songs and also independently published songs and ballads, of which the best-known are 'Terence's Farewell' (1840) and 'The Irish Emigrant' (1845). She entered her long widowhood in 1841, when her husband, by then Baron Dufferin and Claneboye, died after inadvertently taking an overdose of morphia. She had by then formed a particularly close relationship with her son, to whom, as their extensive correspondence illustrates, she dedicated herself until her death from breast cancer in 1867. In 1862 she married a life-long much younger admirer, George Hay, earl of Gifford (1822–1862), then in the final stages of a terminal illness (see inherited his considerable debts on his death two months later). In 1863 her satirical travel book, *Lispings from Low Latitudes, or, Extracts from the*

³³ ODNB.

³⁴ Julian Hawthorne, *Hawthorne and his Circle* (London: Harper & Brothers, 1903), p. 201.

³⁵ Reference to Charles Dickens, *Martin Chuzzlewit* (1843-44), cited in ODNB.

Journal of the Hon. Impulsia Gushington was published and her play *Finesse, or, A Busy Day in Messina*, was performed at the Haymarket Theatre.

Hayward, Abraham (1801-1884), barrister, essayist and translator (79)

A journalist and a self-made man of letters, Hayward probably got to know Norton during the early 1830s, when they moved in similar fashionable circles. He took an interest in her literary work: her first letter to him consists of a note requesting that he return her volume of short stories, *The Coquette and Other Stories* (1835). Hayward remained a loyal friend and, as this thesis reveals, in 1841-2 he presented her appeal for access to the children to the Lord Chancellor, successfully obtaining an out-of-court settlement for shared parental custody. Originally a Tory, like Norton he became a Peelite and then a Liberal and was an equally prolific writer. As he was a lifelong bachelor, she saw no reason to desist from the flirtatious manner she took with him, habitually referring to him as ‘avocat’ (since he hated the use of his first name) and signing herself ‘C. Client’ (as she so often took legal advice from him) and ‘other nomenclatures according to her whims and caprices’.³⁶

Herbert, (Mary) Elizabeth, Lady Herbert of Lea (1822-1911), Roman Catholic convert and philanthropist (5)

Originally dismissive of what she saw as an arranged marriage between Elizabeth À Court Repington and Sidney Herbert (unsurprisingly, as she had hoped to marry him herself), Norton subsequently developed a firm friendship with Elizabeth Herbert. She shared Lady Herbert’s philanthropic concerns and might have sympathised with her conversion to Roman Catholicism in 1866, a path that had been taken by both of Norton’s sons over a decade earlier.

Horne, Richard (1802-1884), writer (1). After serving as a midshipman in the navy, Richard Horne worked on a range of writing projects, from Shelleyesque poems to blank verse historical dramas and occasional articles for a variety of publications. Norton’s only known contact with him was in response to his profile in *A New Spirit of the Age* (1844), his collection of essays on his contemporaries, written in imitation of Hazlitt, where she is compared with Elizabeth Barrett in a chapter in which Horne implicitly comments on Hartley Coleridge’s ranking of the two poets in the *Quarterly Review* (which Horne references). For Coleridge, Norton was ‘the Byron of modern

³⁶ Chessel, p. 99.

poetesses'. He believed that 'the power of thought [...] and the manifold direction of thought which is given to it'³⁷ was nowhere more observable in recent publications by female poets than in *The Dream and Other Poems*. Although Horne sees the two poets as exemplifying different characteristics, he also seems to prefer Caroline: 'Mrs Norton is beautifully clear and intelligible in her narrative and course of thought and feeling; Miss Barret has great inventiveness, but not equal power of construction.'³⁸ On reading *A New Spirit of the Age* therefore, Norton would have had no cause to add to the 'deluge of abuse from its victims' directed at Horne, who 'naïvely surprised, decamped hastily on a tour of Germany'.³⁹

Howard, Hon Henry George (1818-1879), diplomat (17)

The youngest son of the 6th Earl of Carlisle, Howard was appointed attaché to the British Embassy in Paris in 1838 and served until 1846. In May 1845 he married Mary Wellesley McTavish, who he had met in Paris. She was the daughter of John McTavish, British Consul at Baltimore, and Emily Caton, a younger sister of Marianne Caton, one of 'the three American Graces', who married into the English peerage: Marianne had married Richard Wellesley, 1st Marquess of Wellesley. Howard and Mary were married at the Marchioness Wellesley's house in Paris. It appears that Mary desired an acting career and that the marriage was unhappy. She died in Paris in February 1850, aged only twenty-three. Howard was by then Secretary to the Legation at Lisbon, where Norton's elder son Fletcher was one of his colleagues. She became friends with Howard while visiting Fletcher in Portugal during 1848-9. All except two of the letters, which were written from London in January 1850, date from this period.

Le Fanu, Emma (1787-1861) (12)

Emma Le Fanu's father, William Dobbin, knew the Irish Republican rebels, John and Henry Sheares, and Emma was an early supporter of the Irish nationalist cause. She is said to have acquired the dagger that Lord Edward Fitzgerald used to kill one of the British officers, Captain Ryan, sent to arrest him on 19 May 1798 at the house of a Dublin feather merchant.⁴⁰ By her marriage in 1811 to Thomas Le Fanu, Emma strengthened her connection with Fitzgerald: twenty years earlier he had had an affair

³⁷ Hartley Coleridge, 'Modern English Poetesses', *Quarterly Review*, 66.132 (September 1840), p. 376.

³⁸ Richard Horne, *A New Spirit of the Age* (London: Smith, Elder and Co., 1844), Vol. 2, p. 140.

³⁹ *ODNB*.

⁴⁰ S. M. Ellis, *Wilkie Collins, Le Fanu and Others* (London: Constable & Co, 1931), p. 174.

(and a child) with Thomas Le Fanu's aunt, Elizabeth Sheridan (*née* Linley), Richard Brinsley Sheridan's first wife. At the time of their marriage, Thomas Le Fanu was chaplain at the Royal Hibernian Military School. From 1826 to 1845 he was Dean of Emly. Emma and Thomas Le Fanu are now chiefly known as the parents of the Gothic mystery novelist, Joseph Sheridan Le Fanu (1814-1873), renowned as the leading ghost story writer of the nineteenth century.

Le Fanu, William (1816-1894), civil engineer and commissioner of public works (33)

William Le Fanu was chief engineer in the construction of many Irish railways and was for several years Irish Commissioner of Works. His reminiscences, *Seventy Years of Irish Life* (1893), include an anecdote describing a visit he made to Norton in 1861 to establish the meeting place of the Beefsteak Club, which traditionally convened under the roof of a theatre, but which (Norton informed him) had been 'burnt out of old Drury Lane, and out of other theatres'. She did not know their current location but, surprisingly, obtained the information from her maid Cole, whose husband was a freelance waiter 'and might have told her something about this club'. Cole obligingly informed them that the club now met at the Lyceum Theatre.⁴¹ Le Fanu corresponded with Norton from the mid-1840s until shortly before her death. Her final extant letter to him, included in this edition, a powerful statement of her hopes and fears for her forthcoming marriage to Sir William Stirling-Maxwell, illustrates the confidential nature of their correspondence.

Locock, Sir Charles, first baronet (1799-1875), obstetric physician (7)

Locock trained as a doctor, specialising in midwifery, in London, where he swiftly rose to prominence, gaining admittance to the Royal College of Physicians and in 1840 becoming first physician *accoucheur* to Queen Victoria, all of whose births he attended. Norton first called on his professional services in August 1836, when she was living alone in temporary accommodation at 16 Norfolk Street. Such reclusiveness raises the possibility that she was pregnant and had had a miscarriage, as she had experienced in both 1835 and 1828. However, she was frequently unwell, may have shared Locock's hypochondria and certainly valued his diagnosis on the wide variety of the ailments that beset both her and her dependents. These included

⁴¹ William Le Fanu, *Seventy Years of Irish Life* (London: Edward Arnold, 1893), p. 166-7.

Jane Boakes, who she adopted in 1836 and who twenty years later, Norton informed Locock, had ‘apparently causeless, & very bad (nervous, she says) headaches’ (Letter 99). Locock was also a friend to whom Norton confided details of her children’s lives and sent copies of her novels (with the usual caveat that he should not damage sales by lending them to anyone).

Longfellow, William Wadsworth (1807-1882), poet and educator (1)

It is a testament to Norton’s recognition as a poet that she could write to the author of ‘Paul Revere’s Ride’ and *The Song of Hiawatha*, with whom she has not hitherto communicated, as an equal, offering her friendship and a short poem (on which, it would appear, she hoped that he would give his opinion). The reason for the letters was the death in 1861 of Longfellow’s wife Frances from burns received when her dress caught fire. It appears that a correspondence between Norton and Longfellow developed, as the former makes clear in December 1861 (Letter 112) that she intended sending him a copy of her narrative poem *The Lady of Garaye* (1861).

Lytton, Edward Bulwer, first Baron Lytton (1803-1873), writer and politician (15)

Norton had known Edward Bulwer Lytton since she was introduced to society in 1826. He had included a reference to her in the ‘Satiric Sketch’ of Almack’s that featured in his first collection of verse, *Weeds and Wallflowers* (1826). Subsequently his influence and support as a literary editor, critic and politician was very useful to her. There was a genuine friendship, however, and she took his side in the mutually vindictive relationship with his wife Rosina, following the Bulwer Lyttons’ separation in 1827. The surviving correspondence concludes in 1838, but much of it must be missing as Norton mentions seeing him ‘now & then in London’ in a letter to Edward’s son Robert (Letter 136).

Lytton, Robert Bulwer-, first Earl of Lytton (1831-1891), diplomat and poet (4)

Norton became friends with Robert Bulwer-Lytton, the son of Edward Bulwer Lytton and a colleague of her elder son, Fletcher, when the two young diplomats worked together in the 1850s as junior attachés at the British legation in Naples and the embassy in Paris. Bulwer-Lytton also knew Norton’s second son Brinsley and the shared history of the families combines with her real affection for him in warm-hearted letters which contrast with the occasionally equivocal tone of her letters to his father, Edward. She lived to see Lytton appointed viceroy of India and it seems clear

from the tone of her correspondence that she saw in him, as a successful poet and diplomat, the culmination of her frustrated ambitions for her own sons. Moreover, as ‘the child of a broken home’ and a ‘fledgling’ (as he is variously described in her letters to him), he was someone for whom, given how little contact he had with his own mother, she could express a proxy maternal instinct and interest.

Macmillan, Alexander (1818-1896), publisher (26)

The son of a Scottish farmer and carter, Alexander Macmillan worked at a variety of jobs until at the age of twenty-one he joined his elder brother, Daniel, in the Seeley family book-selling business. In 1843 the brothers established a bookshop and small publishing business. The firm prospered and in 1851 Alexander married Caroline Brimley, the daughter of the librarian of Trinity College, Cambridge. The Macmillans ventured into fiction when they bought out Charles Kingsley’s *Westward Ho!* (1855) and Thomas Hughes’s *Tom Brown’s Schooldays* (1857). By 1855 Daniel had been rendered a semi-invalid by tuberculosis and at the time of his death in 1857, Alexander had already taken over responsibility for the business. In 1859 he published the firm’s first novel by a woman, Margaret Oliphant, and later in the year the first issue of *Macmillan’s Magazine* appeared. Norton approached Macmillan’s at this time with her ‘Lives of the Sheridans’, a work she had been planning during the 1850s. When after over a year she did not receive a reply, she sent a very long letter to him, which was published in *Macmillan’s Magazine*,⁴² justifying the need for a new biography of Richard Brinsley Sheridan. Macmillan seems to have been enthusiastic about the work and began advertising ‘Lives of the Sheridans’ before she had started writing it, having been diverted by her narrative poem, *The Lady of Garaye* (1861), which Macmillan also agreed to publish and which went into numerous editions, the last of which he published in 1881. In the letter to him included in this edition (Letter 112), Norton discusses sending copies of the poem to Queen Victoria, Monckton Milnes, Longfellow and ‘a friend or two in various places’. ‘Lives of the Sheridans’ was subsequently delayed by work on *Lost and Saved* (1863) and *Old Sir Douglas* (1867), the latter initially appearing as a serial in *Macmillan’s Magazine*. This projected generational biography was still under discussion in June 1867,⁴³ but never appeared

⁴² CN, ‘Books of Gossip: Sheridan and his Biographers’, *Macmillan’s Magazine*, 3.15 (January 1861), pp. 173-9.

⁴³ CN to Alexander Macmillan, BL, Add MS 54964, f.18.

under her name, although a work with the same title and subject matter, by Percy Fitzgerald, was published by Richard Bentley in 1886.

Melbourne, second Viscount, William Lamb (1779-1848), Prime Minister (57)

William Lamb became friends with Norton's father, Tom Sheridan, when they were both at Trinity College, Cambridge. Subsequently, they were part of the same Whig set, sharing an interest in carousing, singing and staging amateur dramatic performances. He remained a family friend and was commissioned in the early 1820s by Norton's mother, Caroline Sheridan, to write a biography of Richard Brinsley Sheridan, a task passed on to Thomas Moore by Sheridan's executor, John Murray, in March 1824.⁴⁴ It seems likely that Lamb had met Norton by this time, although he does not appear to have started visiting her regularly until the late 1820s. The nature of their relationship is open to question. Certainly by the early 1830s they were widely considered to be lovers, an opinion hardened in many quarters by the testimonies at Lord Melbourne's trial. He had by this time been Prime Minister since April 1835, a position he would hold until August 1841 and which he had previously occupied between July and November 1834. Most of Norton's extant letters to Melbourne have already been published (Hoge and Olney, 1974: see Bibliography); five more are held by the Berg Collection at New York Public Library, while three letters mysteriously excluded from Hoge and Olney's edition are included in this thesis. Letter 54, written three years after he began to distance himself from her following the separation from George Norton, reveals Norton's extreme annoyance with his use of the double-standard and failure to publicly support her.

Milnes, Richard Monckton, first Baron Houghton (1809-1885), author and politician (41)

After studying at Cambridge, London and Bonn universities, Milnes travelled extensively, publishing volumes of poetry drawn from his experiences, although his 'most significant publication was his *Life, Letters and Literary Remains of John Keats* (1848)', which was chiefly responsible for rescuing Keats 'from disparagement as a weak and unhealthy sensualist'.⁴⁵ He also simultaneously pursued a political career, as MP for Pontefract from 1837 to 1863, when he was awarded a peerage.

⁴⁴ Wilfred S. Dowden [ed.], *The Journal of Thomas Moore* (Newark: University of Delaware Press, 1983), Vol. 2, p. 723.

⁴⁵ *ODNB*.

Initially a Peelite, he supported successive Liberal administrations from 1846 onwards, advocating a wide variety of reform causes, but ‘with friends in all camps he was incapable of acrimonious party feeling, which was one reason for his political failure’.⁴⁶ Mixing in the same circles and having similar interests and viewpoints, he and Norton became close friends and corresponded for over forty years. The three letters included in this edition, which represent three decades, are characteristic of her approach to him. Letter 14 features a wide-ranging discussion of poetry and an invitation to a forthcoming social event (‘Lady Mary Fox’s charity bazaar’). Writing to him in 1843 (Letter 66), she invited him to dinner with ‘Dickens de Pickwicko von Chuzzlewit & his dear little wife’. Letter 111, as often in her letters of the 1860s, supplies details of the nervous illness and unhappy history of surviving son, Brinsley.

Munro Ferguson, Emma (1826-1918), amateur painter (38)

Emma Eliza Munro-Ferguson (née Mandeville), of Merton, Surrey, married Colonel Robert Ferguson (*d.* 1868), commander of the 79th Highlanders and Liberal MP for Kirkcaldy (1841-61),⁴⁷ in 1859. Colonel Ferguson is first mentioned by Norton in August 1852, when discussing whether to visit Raith House, his estate at Novar in Ross-shire, during her travels in Scotland.⁴⁸ In 1864, on the death of his first cousin Hugh Andrew Munro, Colonel Ferguson, who already had land in Fife, inherited further estates in Ross-shire and Moray and took the additional surname of Munro. They had three sons and a daughter, their eldest son, Ronald, later became governor-general of Australia and married Lady Helen Hermione Hamilton-Temple-Blackwood, the eldest daughter of Norton’s nephew, Frederick Hamilton-Temple-Blackwood, 1st Marquess of Dufferin and Ava, in 1889. Norton’s extant correspondence with Emma Munro Ferguson (1856-77), who she described as ‘a very clever accomplished woman, one of the finest amateur artists I ever knew & a very pleasant companion’,⁴⁹ suggests a close friendship. They travelled to Cannes together⁵⁰ and on a later visit to Novar, Norton mentions borrowing ‘a black Maltese shawl’⁵¹ from Emma, who the following year drew a likeness of Norton for inclusion

⁴⁶ *Ibid.*

⁴⁷ CN mentions that in the 1857 general election [...] ‘Young Harcourt [...] ran Col. Ferguson very near’ (CN to 5th Duke of Newcastle, [27 April 1857], NUL, Ne/13008).

⁴⁸ CN to Georgia Seymour, 23 August 1852, CBS, Bulstrode Ms, D/RA/A/2B/9/33.

⁴⁹ CN to Robert Bulwer-Lytton, 1 October 1874, HALS, DE/K/C35/37/2.

⁵⁰ CN to Lady Anna Stirling Maxwell, 25 October [1870], ML, T-PM/119/15/17.

⁵¹ CN to Sir William Stirling-Maxwell, 3 October [1871]. ML, T-SK/29/21/299.

in the tailpiece of William Stirling Maxwell's *List of Illustrations and Index* (London: Edinburgh, 1872). Shortly after her second marriage, Norton suggested that Emma Munro Ferguson use one of her stepsons, John and Archie Stirling-Maxwell, as 'a model for "St Michael & all the Angels"' (Letter 155).

Murray, John Samuel (1778–1843), publisher (29)

The only son of the founder of the Murray publishing house and book-selling business, John Murray worked in the family bookshop during the school holidays and became a co-partner of a publishing company at the age of 21, the year that his father died. The business expanded rapidly and in 1809 Murray launched the *Quarterly Review*, a tory response to the *Edinburgh Review*, which he had earlier acquired. He had by this time married Anne Elliot (1782-1845), with whom he had five children. Murray published Byron's *Childe Harold* (1812), cantos i-v of *Don Juan* (1819-21) and first editions of Jane Austen's three later novels. His highly discerning list of authors also included Coleridge, Babbage, Faraday, Malthus and Ricardo. Norton had wanted to be published by him as early as 1829 but had to wait another seven years, when he accepted *Voice from the Factories*.⁵²

Norton, Hon. George (1800-1875), magistrate (35)

The second oldest brother of four boys and girls born in Edinburgh to Fletcher Norton, Baron Exchequer of Scotland, and Caroline Balmain, George Norton attended Winchester School and Edinburgh University. He was called to the Bar in 1825 and elected MP for Guildford in 1826. Subsequently, he was appointed Commissioner for bankrupts in 1827, Recorder for Guildford in 1830 and Metropolitan Police Magistrate for Hackney in 1831, serving until 1844. He later performed the same role in Lambeth from 1845 until 1867. Both before and after his separation from his wife, he appears to have had several mistresses.⁵³ He was particularly vulnerable to criticism by Norton in the early 1850s, when her published censure of him reached a climax, as by then he appears to have established a respectable public reputation as a magistrate. In 1861 Henry Mayhew reported how the 'Hon. G. C. Norton, the "beak" (magistrate), but good for all that' was included by criminals in a 'Court Guide' (which also featured Norton's friends Charles Dickens, Thomas Talfourd and Samuel Rogers) of 'persons known to be

⁵² CN, *A Voice from the Factories* (London: John Murray, 1836).

⁵³ See Chapter 3, Section H.

charitable'.⁵⁴ A street boy whom Mayhew interviewed said he thought the Queen 'hadn't such power [...] as the Lord Mayor, or as Mr. Norton as was the Lambeth beak, and perhaps is still.'⁵⁵ Although Caroline Norton's more recent biographers have noted, in the context of his treatment of his wife, the hypocrisy of some of his judgements, suggesting that his tolerant public image was a façade, reports of the cases over which he presided in both Lambeth and Guildford point to his common sense and concern for the disadvantaged. In February 1839 a man who had lost a forty shilling banknote, which had recently been cashed, successfully appealed to him for assistance.⁵⁶ On a similar occasion, in July 1844, a poor woman with a three-year-old child complained that since the death of her husband the parish officers in Whitechapel, where she lived, were attempting to repatriate her to Ireland, which she had left seventeen years previously. In response, 'Mr Norton humanely offered to supply her with the required funds, and, thinking also that the parish should do something for her, he sent an officer with her to the relieving overseer to communicate that impression.'⁵⁷ On his retirement 'after 37 years' magisterial service [...] from the bench at Lambeth Court [...] a large attendance of professional persons and others bade him farewell', a senior magistrate observing that 'the poor would miss a true and valued friend – one who was ever ready to stretch forth a helping hand to those in distress'.⁵⁸ However, there is nevertheless a marked discrepancy between his public reputation and his continued cruelty, not only to his wife, but also to his son Brinsley, who from November 1859 onwards was heir to the estates of both his father and his uncle, the 3rd Earl Grantley. His father refused to allow him to live in England and eventually managed to secure his disinheritance from everything but the Grantley earldom, by ensuring that his own and Grantley's estates were inherited by Brinsley's own son, Richard. All of Caroline's extant correspondence with her first husband can be traced to two sources: either transcripts of letters he supplied to his lawyers in 1836 as proof of Caroline's supposed insincerity as a wife; or her letters to him, together with his side of the correspondence, as evidence of his unreliable, unreasonable and even threatening approach to custody

⁵⁴ Henry Mayhew, *London Labour and the London poor* (London: Griffin, Bohn and Company, 1861), Vol. 1, p. 314.

⁵⁵ *Ibid*, Vol. 1, p. 474.

⁵⁶ *Times*, 16 February, 1839, p. 7.

⁵⁷ *Times*, 12 July 1844, p. 8.

⁵⁸ *Surrey Advertiser*, 3 August 1867.

negotiations, presented as evidence in her successful Chancery appeal in early 1842 for shared access to her children.

Ogle, Nathaniel (1797-1856), author and steam carriage builder (16)

A relative of Esther Ogle, the second wife of Richard Brinlsey Sheridan, Nathaniel Ogle was a co-owner with William Summers of the Iron Foundry in Southampton. In 1831 the works built two steam engines for road use, which were reported to have travelled between Southampton, London, Oxford, Liverpool and Birmingham ‘at the rate of 24.5 mph loaded with passengers’.⁵⁹ In 1841 Ogle married Helen Acton (1812-1879), with whom he had four children. The family lived in Brentford during the 1840s, but by 1851 were established at St Saviour, Jersey, where Ogle died. In addition to his work as an engineer, he also enjoyed a literary career as the author of *The Life of Addison* (1826), *The Emigrant's Guide to Western Australia* (1839), *Marianne; or the Last of the Asoean Princesses* (1839) and possibly *Memoirs of Monkeys* (1825). Norton’s extant correspondence to him was written between the mid-1830s and mid-1840s. The letter included in this edition features a useful reference to her preparation of affidavits for her appeal to the Chancery Court for access to her children.

Panizzi, Sir Anthony (1797–1879), academic and librarian (8)

Anthony Panizzi was born at Brescello in the duchy of Modena and attended the University of Parma, where it is likely that he joined one of the secret societies founded to advance the cause of Italian unification. In 1822 he left Modena for Switzerland, having been warned that the Italian authorities were preparing to arrest him as an enemy of the regime. He arrived in London in May 1823 and in 1831 joined the British Museum, initially to catalogue books and documents about the French Revolution. He subsequently initiated the compilation of a library catalogue (finally printed between 1880 and 1890) and by the time he was promoted from keeper of printed books to principal librarian in 1856

the number of volumes had increased from 235,000 to 540,000, the number of staff from thirty-four to eighty-nine, considerable progress had been made with the revision of the catalogue, the purchase grant had been increased, the Grenville Library had been received by bequest, the intake of copyright deposit material had been enlarged, and the bulk of the new reading-room and bookstacks had been constructed.⁶⁰

⁵⁹ [http://www.gracesguide.co.uk/Summers and Ogle](http://www.gracesguide.co.uk/Summers_and_Ogle) (accessed 18 November 2015).

⁶⁰ *ODNB*.

For health reasons he had to retire in 1866. The two letters to him included in this edition feature an invitation to dinner with Melbourne and Thackeray, with its comical reference to the former's conviction that the latter was 'a clergyman with whom he is, or ought to be, acquainted' (Letter 72) and a request to help find a job as a porter at the Museum for the husband of her maid (Letter 90).

Peel, Sir Robert, second baronet (1788–1850), prime minister (1)

The son of a manufacturer, landowner and MP, Sir Robert Peel was Prime Minister during December 1834-April 1835 and 1841-6. Norton seems to have been much closer acquainted with Peel's daughter-in-law, Lady Julia Peel, at whose house in Geneva she stayed several times, than with the Prime Minister. Her only known contact with Peel was in 1843, when she asked him if she should be considered for the Poet Laureateship, thus becoming Britain's first female Poet Laureate. It would not then have been considered feasible to nominate a woman for the position (the first female Poet Laureate, Carol Ann Duffy, was not appointed until 2009), which was offered to Wordsworth.

Pelham-Clinton, Henry 5th Duke of Newcastle (1811-1864), politician (47)

Pelham-Clinton was one of a generation of prominent Conservative (later Peelite) politicians from identical educational backgrounds, Eton and Christchurch (the other two were Gladstone and Herbert), elected to Parliament in 1832. Like his two contemporaries, Pelham-Clinton made rapid progress in Peel's administration and as Chief Secretary for Ireland organised famine relief and a programme of public works which 'prevented exceptional suffering during the first half of 1846'.⁶¹ His wife Susan, whom he had married shortly before his election to Parliament, had a series of affairs and the couple were divorced in 1850. On his father's death in 1851 he became the 5th Duke of Newcastle and the following year was appointed Secretary for the Colonies in Aberdeen's administration. Due to the outbreak of the Crimean War in June 1854, he also took control of the War Office, for which the Colonial Secretary had nominal responsibility, although his subordinate Herbert had more experience of army administration. Due to the scandal over the running of the war and the findings of the Roebuck Committee, Newcastle resigned in February 1855. Norton's extant letters to Newcastle were all written between 1850 and 1865 and the two letters written

⁶¹ *ODNB*.

in 1850, one of which is included in this edition (Letter 83), suggest that the relationship was already close. Newcastle had been a colleague of Norton's uncle, Sir James Graham, since 1832. Letter 103, with its casual reference to Gladstone's singing at a Kier house party, or the joking proposal in Letter 115 that the Marquess of Lansdowne, who had been Whig Chancellor as early as 1806, should have left her a legacy, suggest that she at any rate considered herself to be a Liberal Party insider. But a strong sense of a mutual friendship is also communicated, particularly in the later letters, where she shows a genuine concern for his declining health (Letter 117).

Pringle, Thomas (1789–1834), poet, journalist, and philanthropist (2). The son of a Scottish farmer, Thomas Pringle became permanently disabled by an accident at the age of three. He attended Edinburgh University and afterwards pursued a literary career, becoming a friend of Sir Walter Scott, James Hogg and John Lockhart. By 1819 he was married, but his literary career had been unsuccessful and he moved with his large family and an emigrant group to South Africa, where he worked as a librarian in the South African Public Library at Cape Town. He returned to London in 1826 and became Secretary of the Anti-Slavery Society, 'reputedly responsible for producing more than half the organization's multi-varied publications'.⁶² He was the signatory on the Act of Abolition document, published in June 1834, six months before his death. Both of Norton's letters to him were written in July 1830 and concern a poem she wrote for publication in a journal of which he was editor, *Friendship's Offering* (Letter 5).

Russell, Lord John, first Earl Russell (1792–1878), prime minister and author (2). Lord John Russell was born into one of the prominent Whig political dynasties and attended Edinburgh University. In 1813 he became MP for the family seat of Tavistock and in 1822 first advocated electoral reform. He was instrumental in securing the passing of the 1832 Great Reform Act. Defeated in the 1835 South Devon bye-election, despite Norton's attempt to recruit Charles Babbage to campaign for him (Letter 17), he was elected shortly afterwards for Stroud. He is identified as the most likely recipient of Norton's letter of 3 January [1837] (Letter 33), in which she expresses concern for factory conditions and seeks the recipients' interest in her

⁶² *Ibid.*

pamphlet, *Separation of Mother and Child by the Law of Custody of Infants considered* (1837). She certainly wrote to him in December 1859, when he was Foreign Secretary (having served as Prime Minister from 1846 to 1852, as he would from 1865 until 1866). The length and confidential nature of the letter suggests a regular correspondence.

St Maur, Lady Horatia (1819-1915) (1)

Horatia Morier, a granddaughter of Admiral Hugh Seymour married Lord Algernon Seymour (1813-94), a younger brother of Norton's brother-in-law, the 12th Duke of Somerset, in May 1845. She became the Duchess of Somerset when her husband became the 14th Duke on the death of his brother in January 1891. Norton's letter to her reveals her attempt to mend relationships with the 12th Duke's family, which had become embittered by the souring of Norton's relationship with her sister Georgiana, and the conviction of the Duke of Somerset's brothers that 'the Sheridan Duke' was subsidising his wife's family to their own eventual cost.

St Maur, Lady Ulrica (1833-1916) (1)

Ulrica St Maur was the second daughter of Norton's sister Georgiana Seymour, later Duchess of Somerset. The Seymours changed the surname of their children to an older medieval form. Ulrica was a contemporary and near neighbour of Norton's children and became very close to her aunt: Norton's only extant letter to her, which concerns the final illness of her son Fletcher, is characterised by family references, such as to Ulrica's uncle, Charles Kinnaird Sheridan, who died, also of tuberculosis, in the same Paris room as Fletcher. Ulrica married Lord Henry Thynne (1832-1904), the younger son of the Marquess of Bath and MP for South Wiltshire (1859-85), with whom she had five children, in June 1858.

Seymour, Lady Jane Georgiana, Duchess of Somerset⁶³ (1809-1884), Caroline's younger sister (110)

Georgiana Seymour, Caroline Norton's younger sister, lived with her at Rossie Priory between the ages of four and eight and they also both later attended Miss Taylor's school at Wonersh. In 1830 Georgia married Sir Edward Seymour, son and heir to the 11th Duke of Somerset (whose title he inherited in 1855), with whom she had five

⁶³ Georgiana was more usually known as Georgia. Although her first name at birth was Jane, this was not used.

children. While her three daughters made advantageous marriages, both her sons remained single and died in violent circumstances at an early age: her younger son, Edward was killed by a bear in India in 1865, while his older brother, Ferdinand, died as a result of a botched tracheotomy. As children the boys had been playmates of the Queen's sons and throughout her life Georgia enjoyed a highly privileged social position. She had been Queen of Beauty at the 1838 mock-medieval Eglinton Tournament and with her husband was a frequent dinner guest at Windsor Castle. She also exerted political influence through her husband's position as a long-serving MP and promotion in successive Whig administrations. He ultimately served as First Lord of the Admiralty (1859-66) under Palmerston and was considered as a possible unity Prime Minister, until he retired from public life following the death of his younger son. During this time Georgia had a prominent role managing the extensive Somerset family estates.⁶⁴

Shelley, Mary Wollstonecraft (1797-1851), novelist (36)

It seems likely that Norton knew Mary Shelley by July 1832, when the latter's short story 'The Pole' was announced for publication in the August 1832 edition of *The Court Magazine and Belle Assemblée*, although the extant letters were written over an eight-year period between January 1836 and November 1843. Norton had an intense interest in three generations of Mary Shelley's family, which included the novelists' mother, Mary Wollstonecraft, her husband, the iconic poet, and her son and daughter-in-law, Sir Percy and Lady Shelley, with whom she is known to have associated and corresponded in the 1870s.

Sheridan, Caroline Henrietta (1779-1851), novelist (20)

Caroline Sheridan, Norton's mother, was a granddaughter of the 5th Earl of Antrim. Her own mother had died when she was eighteen and she raised her four younger siblings largely unaided by her father, who was often abroad on military missions with the British army. She met her husband, Tom Sheridan, in Edinburgh and they eloped together in 1805. Her husband died in 1817, leaving her, once again, to raise a large family unassisted. In the 1820s she commissioned Thomas Moore to write a biography of her father-in-law, Richard Brinsley Sheridan, and in 1830 she published a novel, *Carwell*, partly set in Australia, followed by two more novels *Aims and Ends* (1833)

⁶⁴ Reynolds, pp. 50-3.

and *Oonagh Lynch* (1833). In the 1840s ill-health and diminishing eyesight made any further writing very difficult and she also suffered the loss from tuberculosis of two of her three remaining sons (her second oldest boy, Tommy, having died at sea in 1824). Her final days were spent in Brighton and at the house of her oldest son, Brinsley, where she died of stomach cancer on 8 June 1851.

Sheridan, Marcia (1814-1884), Norton's sister-in-law (3)

The only daughter and sole heir of General Colquhoun Grant, Marcia Grant became the subject of scandal in 1835, when she eloped to Gretna Green with Brinsley Sheridan, Caroline's elder brother. As a result, General Grant challenged various members of the latter's family, who he rightfully believed had colluded in the affair, to a duel. He finally obtained satisfaction, though there was no injury on either side, from Lord Edward Seymour. Marcia had eight children who survived to adulthood, although her oldest son, Richard Brinsley, died prematurely in violent circumstances at Capri, while visiting his cousin Brinsley Norton, while her second son, Frank, became seriously indebted, served time in prison and died in his thirties.

Stanley, Edward John, second Baron Stanley of Alderley and first Baron Eddisbury (1802-1869) (1)

An 'unexceptional career politician',⁶⁵ Stanley was mentored by Norton's friend Edward Ellice and later by Lord Palmerston, who secured his appointment as Under-secretary of Foreign Affairs in Russell's 1846-52 administration. Norton's only extant letter to him was written during this period. The unreserved and candid quality of her writing strongly suggest that he was a regular confidant.

Stapleton, [?]Harriet⁶⁶ (poet) (1)

Very little is known about Harriet Stapleton, whose Christian name has been deduced from her signature as it has not been possible to verify it from printed records, including census records, where she may have used a married name. She was the grand-daughter of the 2nd Earl of Carnarvon and the daughter of the Rev John C Stapleton and Lady Harriet Elizabeth Herbert (d. 22 November 1836). Her mother was raised at Highclere Castle where she met and married the Rev. Stapleton, a well-connected curate. The couple then lived at Pusey House in Oxfordshire until Lady

⁶⁵ *ODNB*.

⁶⁶ Harriet Stapleton's Christian name deciphered from her signature and because it was also her mother's first name. She was published only as 'Miss Stapleton'.

Harriet's death. By the time of her correspondence with Norton, she had already published several slim volumes of verse, but hoped that a preface from Norton would improve sales of *The Pastor of Silverdale* (1867), which was about to appear in a second edition. Her strategy appears to have been successful as the poem subsequently appeared in several further editions.

Stirling-Maxwell, Anna, Lady (1826-1874), horticulturist (76)

Lady Anna Maria Leslie Melville, one of four daughters of the earl of Leven and Melville and Elizabeth Anne Campbell, married William Stirling at the British embassy in Paris on 26 April 1865, becoming Lady Anna Stirling Maxwell on 6 June 1865, when Stirling succeeded to his uncle's baronetcy. A distant cousin of Stirling, Lady Anna was aged 39 at time of her marriage. She had two children, John (born on 6 June 1866) and Archibald (born on 14 September 1867), to whom Norton became very attached. From early in her marriage she was a friend and confidante of Caroline, who described her as 'decidedly handsome, with delicate regular features, fair hair and high-bred, gentle manners'⁶⁷, as 'very cheery, & very kind'⁶⁸ and as a lover of flowers.⁶⁹ Sir William was out hunting when Lady Anna had the epileptic fit that caused her to fall into the hearth, setting her dress on fire and burning her hand so badly that it had to be amputated. The doctors were still unable to save her life and she died on 8 December 1874.

Stirling-Maxwell, Sir William, ninth Baronet (1818-1878), art historian, historian, and book collector (486)

William Stirling was born into ancient Scottish families through both his paternal and maternal lineage. He inherited a strong royalist tradition on his father's side, while 'his mother's equally ancient family the Maxwells of Pollok...brought different traditions: they had a covenanting past and were reforming whigs, in contrast to the Stirlings' conservatism'.⁷⁰ This helps to explain why Stirling, although for twenty years Conservative MP for Perthshire (1852-68, 1874-78), held generally liberal views. Graduating from Cambridge in 1839, he subsequently embarked on tours of Europe and the Middle East. The outcome of his travels, his *Songs of the Holy Land*

⁶⁷ Perkins, p. 284.

⁶⁸ CN to Emma Munro Ferguson, [19 November] 1865, HL, bMs Eng 1276/183.

⁶⁹ CN to Emma Munro Ferguson, [28 April] 1866, HL, bMs Eng 1276/203.

⁷⁰ *ODNB*.

(1846) and the three-volume *Annals of the Artists of Spain* (1848), ‘by far the most comprehensive and scholarly work in its field in English by that date’,⁷¹ was the first of several books on Spain and Spanish art. He also wrote studies of the Hapsburg rulers Charles V and the latter’s illegitimate son Don John of Austria. The first reference to him in Norton’s correspondence occurs in August 1848, when she declared her plan to visit ‘Stirling of Keir & other outlying friends’, Stirling having succeeded to his father’s estates at Keir and Cawdor in 1847. She was subsequently invited to spend every Autumn at Keir. According to James Pope-Hennessy, Stirling’s ‘fond consistent attachment to Mrs Norton’⁷² had ‘begun with her sincere anxiety to help...“a poor wounded bird” then suffering from a hopeless passion for her sister Helen Dufferin’. In a letter to Monckton Milnes, written in August 1861, Matthew Higgins maintained that, to the attentions of ‘une femme [...] qui l’aime trop’,⁷³ Stirling’s life had become so ‘derangée’⁷⁴ [...] that [...] he is spending the summer in his yacht somewhere in the Baltic – beyond the reach of the post office, & messengers from Chesterfield St’⁷⁵ (Norton’s London address). In 1865 he succeeded to the estates and baronetcy of his uncle Sir John Maxwell and married Lady Anna Maria Leslie Melville. They had two sons, but in 1874 Lady Anna, while having an epileptic fit, fell into an open fire so that her dress caught fire. She died soon after from her injuries. Stirling-Maxwell and Norton were married on 1 March 1877, three months before the latter’s death on 15 June 1877. He died in Venice from a fever exactly seven months later. His considerable legacy included 486 of her letters to him, together with another 76 to his wife and many more from members of the Norton and Seymour families, all of which he had organised into collections relating to individual years.

Temple, Georgina Cowper- Lady Mount-Temple (1821?–1901), religious enthusiast (7)

One prominent theme of Norton’s correspondence with Georgina Cowper-Temple, who had married William Cowper-Temple in 1848, is philanthropy, for which Norton shared the couple’s enthusiasm. She asked Georgina for a circular about the charitable

⁷¹ *Ibid.*

⁷² James Pope Hennessy, *The Flight of Youth* (London: Constable & Company, 1952), p. 48.

⁷³ ‘A woman [...] who loves him too much’ (French).

⁷⁴ ‘Disturbed’ (French).

⁷⁵ Matthew Higgins to Richard Monckton Milnes, 27 August [1862], TCC, Houghton 12/9.

activities of visiting societies, the donation of a superfluous bedstead, or the date of a sale of Polish jewels donated by Polish women ‘for the benefit of their countrymen, who are armed in defence of the common country’,⁷⁶ as a result of the Polish rebellion against Russian rule, finally crushed in 1864. Other letters divulge details of a recent sermon Norton had witnessed or concern poems sent to Georgina. On one occasion, Norton sent her novel *Stuart of Dunleath* for Georgina’s opinion.

Temple, Henry John, third Viscount Palmerston (1784-1865), prime minister (2)
A highly experienced politician, Palmerston had entered the House of Commons at the age of 22 and two years later became Secretary at War, a position he retained under five prime ministers as ‘the need to accommodate others kept him in his old post’.⁷⁷ He led a busy social life and was a notorious womaniser (he was nicknamed Cupid) with a long record of conquests, carried on at the same time as his thirty-year affair with Emily Cowper, wife of the 5th Earl Cowper and sister to Lord Melbourne. He is likely to be the father of at least three of her children, including Norton’s regular correspondent, William Cowper-Temple. Palmerston married Lady Cowper in 1839, having by then served as Foreign Secretary in two successive Whig governments. As Home Secretary in the Aberdeen Coalition (1852-55) and Prime Minister of what became the first Liberal administration, he proved useful to Norton in securing diplomatic posts for her son Fletcher and in supplying her with documents to secure her safe passage through Europe in dangerous times. But perhaps his most significant act of assistance was the forthright leadership he showed the Commons during the summer of 1857 to defeat the filibustering tactics of Gladstone and others to delay, and thus ultimately prevent, the passage of the Divorce and Matrimonial Causes Bill.

Temple, William Francis Cowper-, Baron Mount-Temple (1811-1888), politician (59)

William Cowper-Temple, who is very likely to have been an illegitimate son of Lord Palmerston through the latter’s affair with Lady Emily Cowper, later Cowper-Temple’s step-father, was a prominent Victorian politician. Originally known simply as William Cowper, on his mother’s death in 1869 he ‘inherited under Palmerston’s will many of his estates in Ireland and Hampshire, including Broadlands, at Romsey’

⁷⁶ *London Daily News*, 15 April 1864, p. 5.

⁷⁷ *ODNB*.

and ‘by royal licence...assumed the name Temple in addition to Cowper’.⁷⁸ He became private secretary to his uncle, Lord Melbourne in 1835. Subsequently he was MP for Hertford from 1835 to 1868 and served in successive Whig governments as Lord of the Admiralty (1846-55), President of the Board of Health (1855-58) and commissioner of works (1860-66). The letters show that the friendship was maintained until the 1870s.

Tennyson, Emily (1813-1896), wife of Alfred Tennyson (1)

Emily Tennyson, who married the poet in 1850, may have been one of the reasons that Tennyson’s original hostility to Norton was changed to friendship, a process aided by her adulation for his poetry. She was an occasional guest at the Tennysons’ house at Farringford on the Isle of Wight, sometimes in company with her poet son Brinsley.

Trelawny, Edward John (1792–1881), writer and adventurer (19)

Norton’s romantic friendship with Trelawny lasted about eighteen months, from mid-1835 until early 1837. Like Mary Shelley, he represented a direct link with Shelley and Byron, whose circle held a fascination for her. Her letters to Trelawny illustrate how intrigued she was by both his personality and the tie he had to his iconic contemporaries. He was said to have originally been one of George Norton’s potential correspondents for the 1836 *crim. con.* case, before being discarded on account of his poverty. Norton’s exuberant and indiscreet letters to Trelawny, subsequently posed a threat, should her husband obtain them, to her hopes of regaining access to her children: George Norton could have used them, given Trelawny’s reputation, as proof of her immorality. His refusal to return the letters appears to have cooled the relationship.

Trollope, Frances (1779-1863), travel writer and novelist (2).

Norton persuaded Frances Trollope to write for *The Court Magazine and Belle Assemblée* shortly after the latter’s outspoken views on American manners in *Domestic Manners of the Americans* (1832) had created a sensation on both sides of the Atlantic. Trollope subsequently wrote two stories for the magazine: ‘The Lady and the Major’ (September 1832, pp. 113-15) and ‘The Lake of Canandagua’ [*sic*] (October 1832, pp. 170-77), for which Norton thanked her in the letter (10) reproduced in this edition. The correspondence indicates that the friendship lasted over twenty years. In

⁷⁸ ODNB.

May 1854 Norton reported to her sister Helen, her baggage having left Florence before her: 'Mrs Trollope bid me to a festival, but I said I had no dinner garment.'⁷⁹

⁷⁹ CN to Helen Dufferin, 21 May 1854, PRONI, D1071F/E/1/1.

