

Adaptive Sliding Mode Control Based on Fuzzy Systems Applied to the Permanent Magnet Synchronous Machine

S. Bentouati^{1*}, A. Tlemçani², N. Henini³ and H. Nouri⁴

¹ *Laboratory of Mechanics, Physics, Mathematical Modeling (LMP2M), University of Medea, Medea 26000, Algeria.*

² *Laboratory of Research in Electrotechnics and Automation (LREA) University of Medea, 26000, Algeria.*

³ *Laboratory of Renewable Energies and Materials (LREM), University of Medea, 26000, Algeria.*

⁴ *Power Systems Electronics and Control Research Group, Department of Engineering Design and Mathematics, Bristol, U.K., BS16 1QY.*

Received: August 9, 2021; Revised: October 5, 2021

Abstract: This paper develops an adaptive sliding mode control based on fuzzy systems. In this control technique, the possibilities offered by Sugeno type fuzzy systems, in terms of their ability to approximate continuous nonlinear functions, are exploited, and the Lyapunov theory is used to establish a parametric adaptation law ensuring the global stability of the system. In addition, the control law includes a sliding mode term, which has the role of compensating the effects of the reconstruction errors. This technique is applied to control a permanent magnet synchronous machine. The results obtained show the effectiveness of the proposed method.

Keywords: *fuzzy systems; fuzzy adaptive law; sliding mode; reconstruction errors; permanent magnet synchronous machine.*

1 Introduction

The use of classical control techniques (proportional, integral and/or derivative actions control) requires knowing the system parameters in order to set the appropriate control parameters which permit reaching the desired goal. Thus, errors and inaccuracies might well happen during the process. Moreover, the control is hard due to the existing coupling between the variables of the system (interaction between the variables to be controlled). Yet nevertheless, using the so-called robust control methods including adaptive control can help solve the problem. Recent contributions in adaptive control, both theoretical and practical, have allowed to better understand adaptive systems [1–4]. The main purpose of adaptive control is the synthesis of adaptation laws to automatically adjust regulators of the control loops in order to achieve or maintain a given level of performance, when the parameters of the process to be controlled are unknown or little known [5–9]. Indeed, a large research effort is invested in understanding the structural and functional aspects of biological systems and in particular the processes of the human brain. This led to try new ways which integrate the non-linearities and uncertainties inherent in the real system. The fuzzy systems approach seems to be practical, and studies have shown that certain classes have the quality of being universal function approximators [10–16]. This important property has opened a new way to use fuzzy systems in the field of control [1–4]. Hence, several works are oriented towards combining fuzzy systems with control techniques such as adaptive control. In these control schemes, fuzzy systems are used to approximate non-linear functions. In this paper, an adaptive control based on fuzzy systems is developed. Fuzzy systems are used to approximate the model of the system to be controlled, and in order to compensate the effects of reconstruction errors, we introduce a sliding mode term in the control law. The approximation theory and the Lyapunov theory are used to establish a parametric adaptation law ensuring the boundedness of all the signals of the system and the error of the fuzzy system parameters.

2 Description of The Sugeno Type Fuzzy System

The fuzzy system in its design consists of four main modules [17–20]: 1) the fuzzy rule base, or knowledge base, contains the fuzzy rules describing the behavior of the system; 2) the fuzzy inference engine transforms, with the help of fuzzy reasoning techniques, the fuzzy part resulting from the fuzzification into a new fuzzy part; 3) the fuzzification transforms the physical input quantity into a fuzzy quantity; 4) the defuzzification transforms the fuzzy quantity resulting from the inference into a physical quantity. There is a great number of possibilities of realization of fuzzy systems with a multitude of choices for each, and each combination of choices generates a class of fuzzy systems. In our work, we are interested in the Sugeno type fuzzy system, initially developed by Sugeno and Takagi for modeling of systems from numerical data [21]. In this case the consequences of the rules are numerical functions, which depend on the current values of the input variables. In this way, the defuzzification step required by other fuzzy systems is skipped. As our goal is to develop a law of adaptation of the parameters of the fuzzy system, it is therefore essential to give the analytical expression of the output of Sugeno's fuzzy system, to approximate any nonlinear function from numerical data.

Let us denote by $x_{sf_1}, \dots, x_{sf_n}$ the inputs of Sugeno's fuzzy system, and by y_{sf} its output. For each variable x_{sf_i} is associated m_i fuzzy sets F_i^j in universe of discourse U_i such that for any x_{sf_i} in U_i , there exists at least one degree of membership. $\mu_{F_i^j}(x_{sf_i}) \neq 0$,

where $i = 1, 2, \dots, n$ and $j = 1, 2, \dots, m_i$. The rule base of the fuzzy system includes $M = \prod_{i=1}^n m_i$ rules such as

$$R_l : \text{if } x_{sf_1} \text{ is } F_1^{l1} \text{ and...and } x_{sf_i} \text{ is } F_i^{li} \text{ and...and } x_{sf_n} \text{ is } F_n^{ln} \text{ then } y_{sf_l}(x) = a_0^l + \dots + a_n^l x_{f_n}. \quad (1)$$

Each fuzzy rule R_l corresponds to a combination of $(F_1^{l1}, \dots, F_i^{li}, \dots, F_n^{ln})$ fuzzy sets. In fact, the knowledge base contains all possible combinations of the fuzzy sets of the input variables. In this case, the consequences of the rules are numerical functions, which depend on the current values of the observation variables $(x_{sf})_{i=1, \dots, n}$. From the previous set of rules, the expression for the final output is given by the following relationship [16, 18, 22]:

$$y_{sf} = \frac{\sum_{l=1}^M \mu_l y_{sf_l}}{\sum_{l=1}^M \mu_l} \quad (2)$$

with

$$\mu_l = \prod_{i=1}^n \mu_{F_i^{li}}(x_i), \quad 1 \leq l_i \leq m_i. \quad (3)$$

This represents the degree of confidence or activation of the rule R_l . Since each rule has a numerical conclusion, the total output of the fuzzy system is obtained by calculating a weighted average, and in this way, the time consumed by the defuzzification procedure is avoided. The membership functions characterizing the fuzzy sets F_i^j are chosen based on Gaussian functions defined by the following relation:

$$\mu_{F_i^j}(x_{sf_i}) = \exp(-0.5(v_i^j(x_{sf_i} - c_i^j))), \quad (4)$$

where c is the mean, v is the inverse of the variance. In the case where the parameters of the premises are a priori fixed, the only adjustable parameters will be those of the conclusion. Thus, the final output can be written in the following form:

$$y_{sf} = W(x_{sf})A, \quad (5)$$

where A is a vector of parameters a_i^j , and $W(x_{sf})$ is a vector of fuzzy basis functions, $l = 1, \dots, M$; $i = 1, \dots, n$; and $1 \leq l_i \leq m_i$.

3 Adaptive Control Based on Fuzzy Systems

3.1 Formulation of the problem

Let us define a nonlinear system by the collection of m differential equations of order n such as

$$u_i = F_i(X)x_i^{(n)} + G_i(X), \quad (6)$$

$y_i = x_i$; $i = 1, \dots, m$, $X = [x^{(n-1)}, \dots, x]^T$, $x = [x_1, \dots, x_m]^T$, $u = [u_1, \dots, u_m]^T$, and $y = [y_1, \dots, y_m]^T$ are, respectively, the state vector, the input vector and the output vector. Moreover, we assume that the time derivative of $F_i(X)$ verifies the following condition:

$$|F_i(X)| \leq F_{i0} \|X\|, \quad (7)$$

where F_{i0} is a known positive constant. To help establishing the control law, we introduce the following definitions:

- The tracking error vector $e_i = [e_i \ \dot{e}_i \ \dots \ e_i^{(n-1)}]^T \in \mathcal{R}^m$ with $e_i = x_{id} - x_i$.
- The filtered tracking error

$$s_i = \left(\frac{\partial}{\partial t} + \lambda \right)^{(n-1)} e_i \quad (8)$$

can be written as $s_i = C_i e_{i0}$, where $C_i = [\lambda^{(n-1)} \ (n-1)\lambda^{n-2} \ \dots \ 1]$.

- The reference signal

$$y_{ir}^{(n)} = x_{id}^{(n)} + C_{ir} e_i \quad (9)$$

with $C_{ir} = [0 \ \lambda^{(n-1)} \ (n-1)\lambda^{(n-2)} \ \dots \ (n-1)\lambda]$ and $x_{id}^{(n)}$ being the n^{th} derivative of the reference x_{id} .

To synthesize the control law, the functions $F_i(X)$ and $G_i(X)$ are replaced by two Sugeno fuzzy systems of the form $W(X)\theta$ such as

$$F_i(X) = W_{f_i}(X)\theta_{f_i} + \varepsilon_{f_i} \quad (10)$$

$$G_i(X) = W_{g_i}(X)\theta_{g_i} + \varepsilon_{g_i}, \quad (11)$$

where ε_{f_i} and ε_{g_i} are the reconstruction errors of functions $F_i(X)$ and $G_i(X)$ such that [4]

$$|\varepsilon_{f_i}| \leq \bar{\varepsilon}_{f_i} \quad (12)$$

$$|\varepsilon_{g_i}| \leq \bar{\varepsilon}_{g_i}. \quad (13)$$

We denote the estimate of the function $F_i(X)$ by $\hat{F}_i(X)$ and $G_i(X)$ by $\hat{G}_i(X)$ such that

$$\hat{F}_i(X) = W_{f_i}(X)\hat{\theta}_{f_i} \quad (14)$$

$$\hat{G}_i(X) = W_{g_i}(X)\hat{\theta}_{g_i}. \quad (15)$$

The adaptive fuzzy control problem is posed as follows. For the nonlinear system defined by equation (6), determine the adjustment laws of the parameters of the two fuzzy systems that allow to estimate, online, the functions $F_i(X)$ and $G_i(X)$ as well as the adequate control u_i such that the tracking error converges asymptotically to zero.

3.2 Synthesis of the control law

Our goal is to design a control such that the tracking error converges asymptotically to zero. Thus, this control is given by

$$u_i = k_{id}s_i + \frac{1}{2}F_{i0} \|X\| s_i + W_{f_i}(X)\hat{\theta}_{f_i}y_{ir}^{(n)} + W_{g_i}(X)\hat{\theta}_{g_i} + K_i \text{sign}(s_i), \quad (16)$$

where K_i is the sliding mode term, it is given by

$$K_i = \bar{\varepsilon}_{f_i} |y_{ir}^{(n)}| + \bar{\varepsilon}_{g_i}. \quad (17)$$

The parameters of the fuzzy systems are adjusted by the following adaptation laws:

$$\dot{\hat{\theta}}_{f_i} = \eta_{f_i} W_{f_i}^T(X) s_i y_{ir}^{(n)}, \quad (18)$$

$$\dot{\hat{\theta}}_{g_i} = \eta_{g_i} W_{g_i}^T(X) s_i. \quad (19)$$

The schematic diagram of adaptive control based on fuzzy systems is shown in Figure 1.

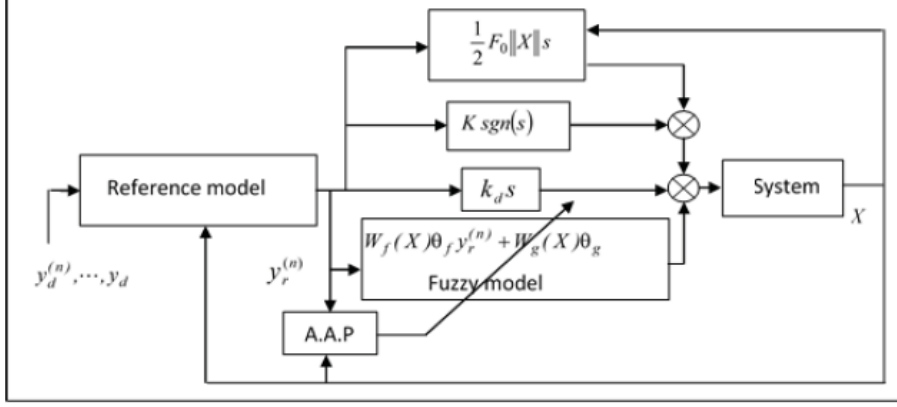

Figure 1: Structure of adaptive control based on fuzzy systems.

4 Study of the Stability

Using the control law (16) and the dynamic model of the nonlinear system (6), and knowing that $y_{ir}^{(n)} = y_i^{(n)} + \dot{s}_i$, the dynamics of the error is given by

$$F_i \dot{s}_i = -k_{id} s_i - \frac{1}{2} F_{i0} \|X\| s_i - W_{f_i}(X) \tilde{\theta}_{f_i} y_{ir}^{(n)} - W_{g_i}(X) \tilde{\theta}_{g_i} - k_i \text{sign}(s_i) + \varepsilon_{f_i} y_{ir}^{(n)} + \varepsilon_{g_i}, \quad (20)$$

where $\tilde{\theta}_{f_i}$ and $\tilde{\theta}_{g_i}$ are the parametric errors, they are given by $\tilde{\theta}_{f_i} = \hat{\theta}_{f_i} - \bar{\theta}_{f_i}$ and $\tilde{\theta}_{g_i} = \hat{\theta}_{g_i} - \bar{\theta}_{g_i}$ with $\bar{\theta}_{f_i}$ and $\bar{\theta}_{g_i}$ being the parameter vectors for the reconstruction errors to be zero.

Let the following Lyapunov function:

$$V = \frac{1}{2} s_i^2 F_i + \frac{1}{2} (\tilde{\theta}_{f_i}^T \eta_{f_i}^{-1} \tilde{\theta}_{f_i}) + \frac{1}{2} (\tilde{\theta}_{g_i}^T \eta_{g_i}^{-1} \tilde{\theta}_{g_i}). \quad (21)$$

By deriving (21) with respect to time, we obtain

$$\dot{V} = \frac{1}{2} \dot{s}_i^2 F_i + s_i \dot{F}_i \dot{s}_i + \tilde{\theta}_{f_i}^T \eta_{f_i}^{-1} \dot{\tilde{\theta}}_{f_i} + \tilde{\theta}_{g_i}^T \eta_{g_i}^{-1} \dot{\tilde{\theta}}_{g_i}. \quad (22)$$

Replacing (20) in (22), we have

$$\begin{aligned} \dot{V} = & \frac{1}{2} \dot{s}_i^2 \dot{F}_i - s_i^2 k_{id} - \frac{1}{2} \dot{s}_i^2 F_{i0} \|X\| - s_i W_{f_i}(X) \tilde{\theta}_{f_i} y_{ir}^{(n)} - s_i W_{g_i}(X) \tilde{\theta}_{g_i} \\ & + \tilde{\theta}_{f_i}^T \eta_{f_i}^{-1} \dot{\tilde{\theta}}_{f_i} + \tilde{\theta}_{g_i}^T \eta_{g_i}^{-1} \dot{\tilde{\theta}}_{g_i} + s_i \varepsilon_{f_i} y_{ir}^{(n)} + s_i \varepsilon_{g_i} - s_i K_i \text{sign}(s_i). \end{aligned} \quad (23)$$

To facilitate the demonstration, we make the following decomposition:

$$\dot{V}_1 = -s_i^2 k_{id},$$

$$\dot{V}_2 = \frac{1}{2} \dot{s}_i^2 \dot{F}_i - \frac{1}{2} \dot{s}_i^2 F_{i0} \|X\|,$$

$$\dot{V}_3 = s_i W_{f_i}(X) \tilde{\theta}_{f_i} y_{ir}^{(n)} + \tilde{\theta}_{f_i}^T \eta_{f_i}^{-1} \dot{\tilde{\theta}}_{f_i} - s_i W_{g_i}(X) \tilde{\theta}_{g_i} + \tilde{\theta}_{g_i}^T \eta_{g_i}^{-1} \dot{\tilde{\theta}}_{g_i}.$$

Thus, the expression of \dot{V} is put in the following form:

$$\dot{V}_4 = s_i \varepsilon_{f_i} y_{ir}^{(n)} + s_i \varepsilon_{g_i} - s_i K_i \text{sign}(s_i),$$

$$\dot{V} = \dot{V}_1 + \dot{V}_2 + \dot{V}_3 + \dot{V}_4.$$

Knowing that k_d is a positive constant, we get $\dot{V}_1 \leq 0$. Using condition (7), we have $\dot{V}_2 \leq 0$.

Following the adaptation laws in (18), and (19), we obtain $\dot{V}_3 \leq 0$. According to the expression of the slip mode term (16), it comes $\dot{V}_4 \leq 0$. Hence, the time derivative of the Lyapunov function verifies

$$\dot{V} \leq 0. \quad (24)$$

The inequality (24) implies that s converges asymptotically to zero and that all signals in the system are bounded.

4.1 Application to the permanent magnet synchronous machine

The machine model is established by considering the commonly accepted simplifying assumptions that the machine is of symmetric, unsaturated construction and that the iron losses and space harmonics of the magnetic field are negligible. The dynamics of the machine is represented by its rotor-related PARK model [23–25] so that the electrical quantities appear in a continuous form, easy to process by the control algorithm. Thus, this model is given by

$$\begin{cases} v_d &= R_s i_d + L_d \frac{di_d}{dt} - pL_q \Omega i_q, \\ v_q &= R_s i_q + L_q \frac{di_q}{dt} + pL_d \Omega i_d + p\Omega \Phi_f, \\ j \frac{d\Omega}{dt} &= T_{em} - T_r - F_c \Omega, \\ T_{em} &= \frac{3}{2} p (\Phi_f i_q + (L_d - L_q) i_d i_q), \end{cases} \quad (25)$$

where Φ_f is the total permanent magnet flux, (L_d, L_q) are the forward and quadrature inductances, (i_d, i_q) are the stator current components, (v_d, v_q) are the stator voltage components, R_s is the stator resistance, Ω is the rotational speed, F_c is the strongly viscous coefficient, j is the moment of inertia, T_r is the resistive torque and p is the number of pole pairs.

4.2 Speed control

In the case of a permanent magnet synchronous machine without salience ($L_d = L_q$) and without dampers, the electromagnetic torque depends only on the q-axis current component. The power input is optimized for a given torque if the disturbance current $i_d = 0$, [26]. The control must maintain zero and adjust the torque with. Physically, this strategy amounts to maintaining the armature reaction flux in quadrature with the rotor flux produced by the system. The overall structure of this command is shown in Figure 2. A coordinate transformation (dq -abc) is used to calculate the reference stator currents. These currents are compared to the actual measured currents to set the control of each inverter arm. Using the equilibrium equation between the driving torque and the torque opposed by the mechanical part of the system, we can write

$$i_q = F(\Omega) \frac{d\Omega}{dt} + G(\Omega). \quad (26)$$

The implementation of this command requires the approximation of the functions $F(\Omega)$ and $G(\Omega)$ by the fuzzy systems, thus, this approximation is given by

$$F(\Omega) = W_f(\Omega) \theta_f + \varepsilon_{f\Omega}, \quad (27)$$

$$G(\Omega) = W_g(\Omega) \theta_g + \varepsilon_{g\Omega} \quad (28)$$

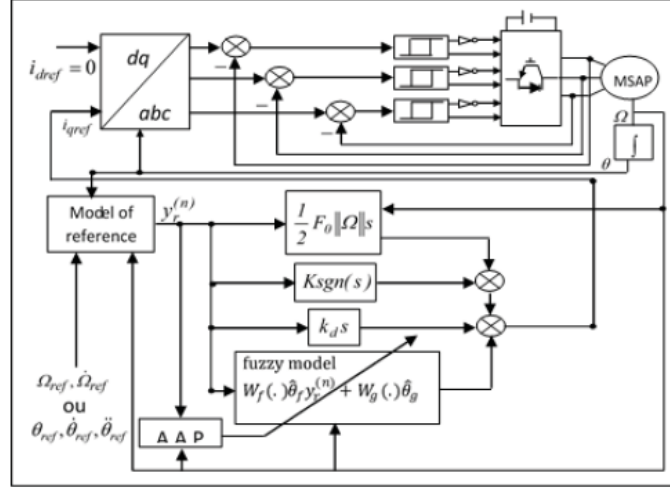

Figure 2: Speed/position control structure by the adaptive control method based on fuzzy systems.

with $\varepsilon_{f\Omega}$ and $\varepsilon_{g\Omega}$ being the reconstruction errors of functions $F_i(\Omega)$ and $G_i(\Omega)$ such that $|\varepsilon_{f\Omega}| \leq \bar{\varepsilon}_{f\Omega}$, $|\varepsilon_{g\Omega}| \leq \bar{\varepsilon}_{g\Omega}$.

In this approximation, we choose two Sugeno fuzzy systems of order one having the input. Three membership functions are associated to this input. Thus, we have three rules for each fuzzy system.

The estimated functions generated by the fuzzy systems are given by

$$\hat{F}(\Omega) = W_f(\Omega)\hat{\theta}_f, \quad (29)$$

$$\hat{G}(\Omega) = W_g(\Omega)\hat{\theta}_g, \quad (30)$$

where $\hat{\theta}_f$ and $\hat{\theta}_g$ are the internal parameters of the fuzzy systems, they are adjusted by the following adaptation law:

$$\dot{\hat{\theta}}_f = \eta_{f\Omega} W_f^T(\Omega) s \dot{y}_r, \quad (31)$$

$$\dot{\hat{\theta}}_g = \eta_{g\Omega} W_g^T(\Omega) s, \quad (32)$$

where $\eta_{f\Omega}$ and $\eta_{g\Omega}$ are positive constants, s and \dot{y}_r are, respectively, the error and the reference signal, their expressions are given by $s = \Omega_{ref} - \Omega$, $\dot{y}_r = \dot{\Omega}_{ref}$.

From the estimated fuzzy functions, the law control has the following form:

$$i_{q,ef} = k_d \Omega s + \frac{1}{2} F_{0\Omega} \|\Omega\| s + W_f(\Omega)\hat{\theta}_f \dot{y}_r + W_g(\Omega)\hat{\theta}_g + k_\Omega \text{sign}(s), \quad (33)$$

where k_Ω is the gain of the slip mode term, its expression is given by $k_\Omega = \bar{\varepsilon}_{f\Omega} |\dot{y}_r| + \bar{\varepsilon}_{g\Omega}$.

4.3 Position control

The schematic diagram of this control is shown in Figure 2. Through fuzzy systems, the functions $F(\dot{\theta})$ and $G(\dot{\theta})$ in equation (26) are approximated as follows:

$$F(\dot{\theta}) = W_f(\dot{\theta})\theta_f + \varepsilon_{f\theta}, \quad (34)$$

$$G(\dot{\theta}) = W_g(\dot{\theta})\theta_g + \varepsilon_{g\theta}, \quad (35)$$

with $\varepsilon_{f\theta}$ and $\varepsilon_{g\theta}$ being the reconstruction errors of functions $F(\dot{\theta})$ and $G(\dot{\theta})$ such that $|\varepsilon_{f\theta}| \leq \bar{\varepsilon}_{f\theta}$, $|\varepsilon_{g\theta}| \leq \bar{\varepsilon}_{g\theta}$.

In our application, two Sugeno fuzzy systems of order one with three fuzzy rules are used to approximate the functions $F(\dot{\theta})$ and $G(\dot{\theta})$. The fuzzy systems generate the estimated functions $\hat{F}(\dot{\theta})$ and $\hat{G}(\dot{\theta})$ such that

$$\hat{F}(\dot{\Omega}) = W_f(\dot{\Omega})\hat{\theta}_f, \quad (36)$$

$$\hat{G}(\dot{\Omega}) = W_g(\dot{\Omega})\hat{\theta}_g, \quad (37)$$

where $\hat{\theta}_f$ and $\hat{\theta}_g$ are the internal parameters of the fuzzy systems, they are adjusted by the following adaptation law:

$$\dot{\theta}_f = \eta_{f\theta} W_f^T(\theta) s \ddot{y}_r, \quad (38)$$

$$\dot{\theta}_g = \eta_{g\theta} W_g^T(\theta) s, \quad (39)$$

where s and \ddot{y}_r are, respectively, the filtered error and the reference signal, they are given by $s = \dot{\theta}_{ref} - \dot{\theta} + \lambda(\theta_{ref} - \theta)$, $\ddot{y}_r = \ddot{\theta}_{ref} + \lambda(\dot{\theta}_{ref} - \dot{\theta})$, whereas $\eta_{f\theta}$ and $\eta_{g\theta}$ are positive constants. Based on the estimated fuzzy functions, the adaptive controller provides the command i_{qref} , which is given by

$$i_{qref} = k_{d\theta} s + \frac{1}{2} F_{0\theta} \left\| \dot{\theta} \right\| s + W_f(\dot{\theta})\hat{\theta}_f \ddot{y}_r + W_g(\dot{\theta})\hat{\theta}_g + k_{\theta} \text{sign}(s), \quad (40)$$

where K_{θ} is the gain of the slip mode term, it is given by $K_{\theta} = \bar{\varepsilon}_{f\theta} |\ddot{y}_r| + \bar{\varepsilon}_{g\theta}$.

5 Numerical Simulation

In this section, we present the results obtained from the simulation of the adaptive control technique based on fuzzy systems applied to the permanent magnet synchronous machine. The values of the tuning coefficients, imposing the desired dynamics, are gathered in Tables 1 and 2.

$\eta_{f\Omega}$	$\eta_{g\Omega}$	$k_{d\Omega}$	$F_{0\Omega}$	$\bar{\varepsilon}_{f\Omega}$	$\bar{\varepsilon}_{g\Omega}$
0.05	0.05	1	0.05	0.01	0.01

Table 1: Speed adjustment coefficients.

$\eta_{f\theta}$	$\eta_{g\theta}$	$k_{d\theta}$	$F_{0\theta}$	$\bar{\varepsilon}_{f\theta}$	$\bar{\varepsilon}_{g\theta}$	λ
50.1	50.1	10	10	0.1	0.1	70.8

Table 2: Position adjustment coefficients.

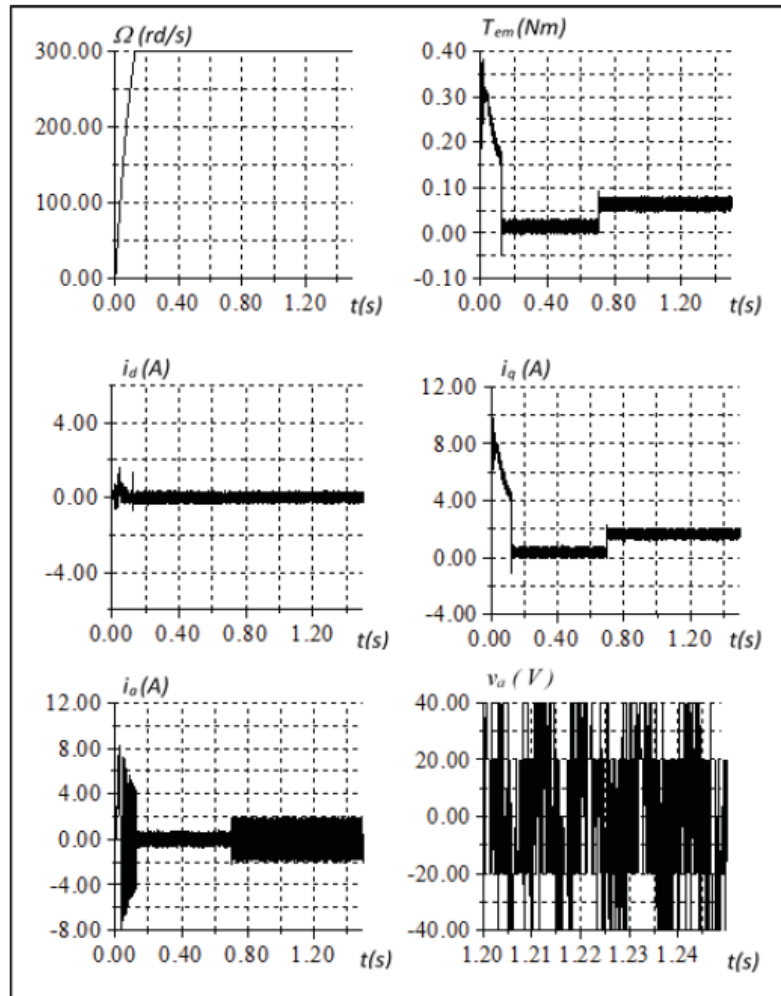

Figure 3: Dynamic behavior of the MSAP during a start-up with load variation at time $t = 0.7$ s.

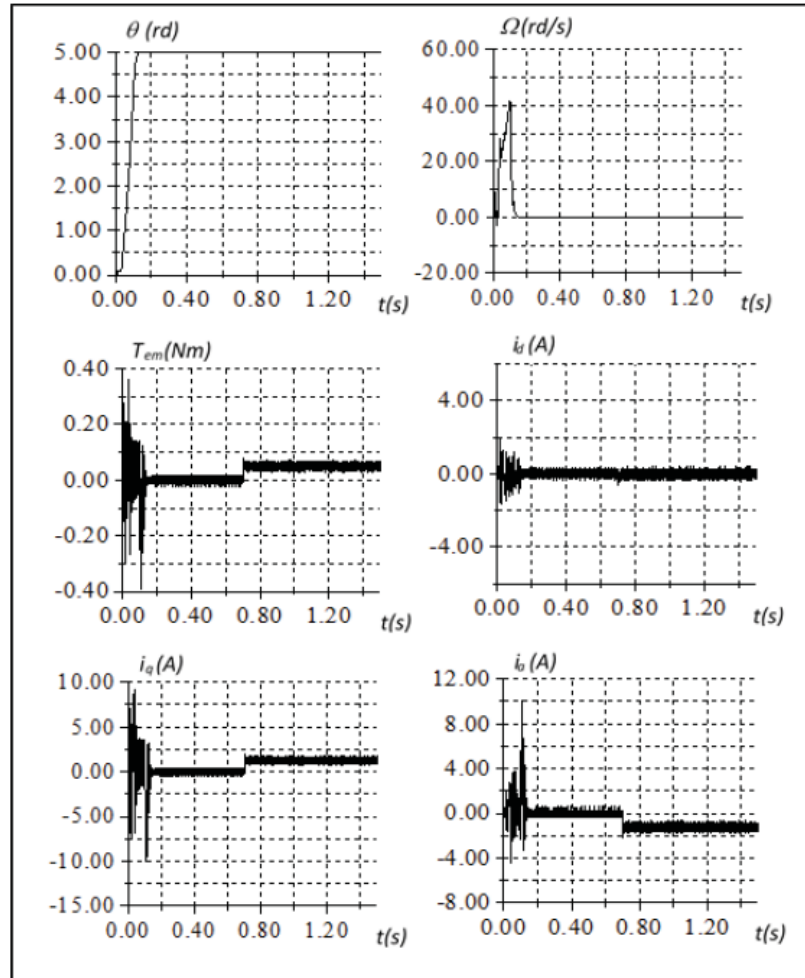

Figure 4: Dynamic behavior of the MSAP during positioning with load variation at time $t = 0.7$ s.

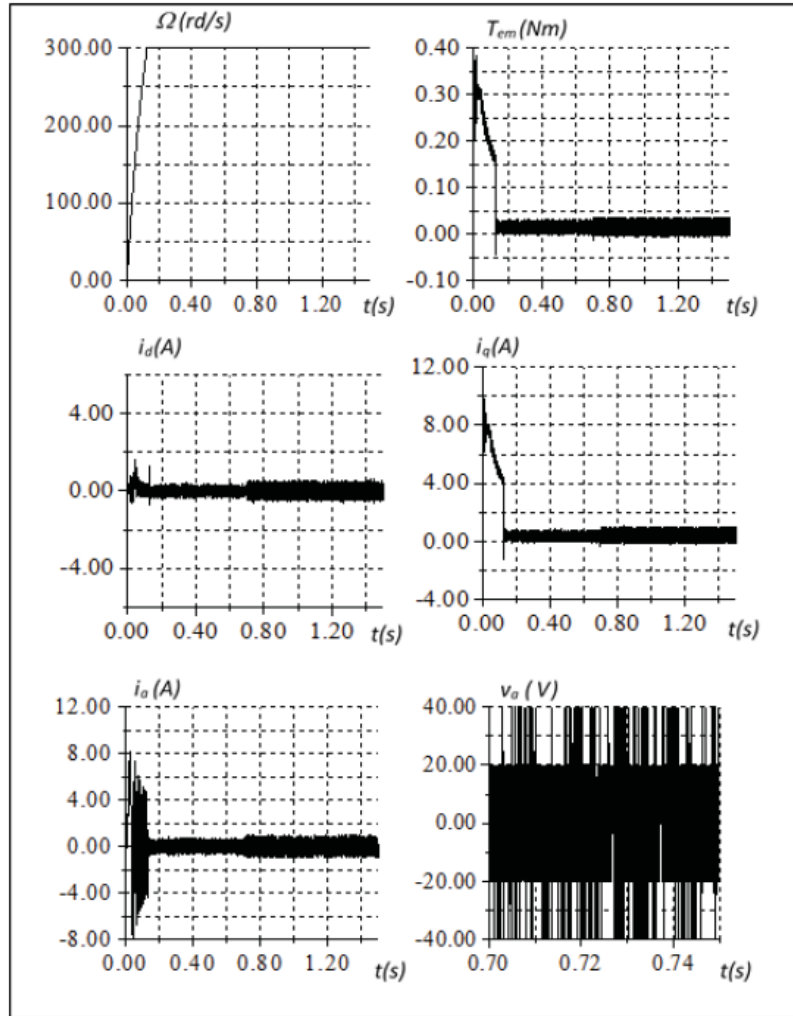

Figure 5: Dynamic behavior of the MSAP during a start-up with parametric variations at time $t = 0.8$ s.

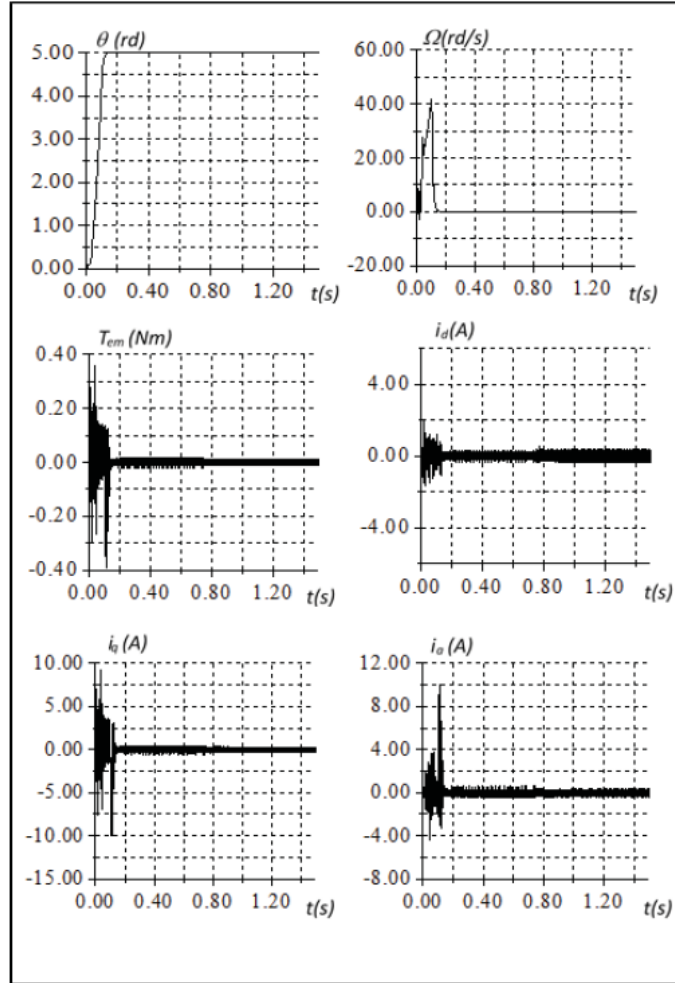

Figure 6: Dynamic behavior of the MSAP during positioning with parametric variations at time $t = 0.8$ s.

Figure 3 shows the responses obtained during a start-up for a speed setpoint of 300 rd/s with load variation. Figure 4 gives the responses obtained during positioning. We note very interesting dynamic and static performances, the disturbance rejection is effective, the decoupling of the d - q axes is not affected by the severe regime applied to the machine. The speed and position drops are of the order of 0.076 and 0.03, respectively. The times required to compensate for these are equal to 0.002s and 0.016s, respectively. To evaluate the performance of this control scheme with respect to parametric variations, we have tested the influence of parametric variations on the performance of the speed and position control. We consider variations on the stator resistance, on the inductances as well as on the magnet flux. The stator resistance is varied by 100, the inductances

are varied by -50 , and the magnet flux by -10 . The obtained responses are shown in Figures 5 and 6. From these results, we notice that the adaptive control based on fuzzy systems presents a strong robustness towards parametric variations, which proves the effectiveness of this control technique.

6 Conclusion

In this paper, we have presented and applied a new approach of adaptive control based on fuzzy systems, in order to control the speed and position of the permanent magnet synchronous machine. The fuzzy systems are used to approximate the non-linear functions, which are determined by a self-learning or self-tuning according to a law that ensures the global stability of the system. In the light of the recorded responses, the proposed adaptive control based on fuzzy systems presents good performances. Indeed, the tests carried out on the model of the synchronous machine with permanent magnets, allowed us to judge positively the stability and the effectiveness of this algorithm.

References

- [1] C. Y. Su and Y. Stephanenko. Adaptive control of a classe of non linear systems with fuzzy logic. *IEEE Tran. on Fuzzy Systems* **2** (2) (1994) 285–294.
- [2] Y. T. Kim and Z. Bien. Robust Indirect Adaptive Fuzzy Control. *Proc. IEEE Int. Conf. on Fuzzy Systems. Seoul, Korea* (1999) 1293–1298.
- [3] Y. W. Cho, Y. H. Yee and M. Park. An Indirect Model Reference adaptive Fuzzy Control for SISO Takagi-Sugeno Model. *Proc. IEEE Int. Conf. on Fuzzy Systems. Seoul, Korea* (1999) 474–479.
- [4] L. X. Wang. Stable Adaptive Fuzzy Control of Nonlinear Systems. *IEEE Tran. On Fuzzy Systems* **1** (1) (1993) 146–155.
- [5] M. Ming, W. Liang, Z. Feng, J. Ling, A. Mamun and X. Xiao. PID-type sliding mode-based adaptive motion control of a 2-DOF piezoelectric ultrasonic motor driven stage. *Mechatronics* **76** (2021) 102543.
- [6] Z. Ning, B. Cai, R. Weng, L. Zhang and S. F. Su. Stability and control of Fuzzy Semi-Markov Jump Systems Under Unknown Semi-Markov Kernel. *IEEE Transactions on Fuzzy Systems* (2021).
- [7] R. P. Noronha. Diversity Control in the Hybridization GA-PSO with Fuzzy Adaptive Inertial Weight. *5th International Conference on Intelligent Computing and Control Systems (ICICCS) IEEE* (2021) 1055–1062.
- [8] Q. Shi, H. K. Lam, C. Xuan and M. Chen. Adaptive neuro-fuzzy PID controller based on twin delayed deep deterministic policy gradient algorithm. *Neurocomputing* **402** (2020) 183–194.
- [9] T. S. Mohamed, and E. Miler. Daniel. Adaptive Control of a class of discret-time nonlinear systems yielding linear-like behavior. *Automatica, Elsevier* **130** (2021) 109691.

- [10] F. Hamidia, A. Abbadi, A. Tlemçani and M. S. Boucherit. Dual star induction motor supplied with double photovoltaic panels based on fuzzy logic tupe-2. *Nonlinear Dynamics and Systems Theory* **18** (4) (2018) 359–371.
- [11] A. Morceli, A. Tlemçani and M. S. Boucherit. Shunt Active Power Filter Based Harmonics Compensation of Low-Voltage Network Using Fuzzy Logic System. *Nonlinear Dynamics and Systems Theory* **17** (1) (2018) 70–85.
- [12] X. Zeng and M. G. Singh. Approximation theory of fuzzy systems-MIMO case. *IEEE Transaction on Fuzzy Systems* **3** (2) (1995) 219–235.
- [13] X. Zeng and M. G. Singh. Approximation accuracy analysis of fuzzy systems as function approximators. *IEEE Transactions on Fuzzy Systems* **4** (1) (1996) 44–63.
- [14] A. Shmilovici and O. Z. Maimon. Fuzzy systems approximation by frames-SISO case. In: *Proc. of 1995 IEEE Intern. Conf. on Fuzzy Systems*, 1995, vol. 4, 2057–2062.
- [15] H. Ying. General SISO Takagi-Sugeno fuzzy systems with linear rule consequent are universal approximators. *IEEE Transactions on Fuzzy Systems* **6** (4) (1998) 582–587.
- [16] B. Kosko. *Neural Networks and Fuzzy Systems: A Dynamical Approach to Machine Intelligence*. Prentice Hall, 1992.
- [17] J. M. Mendel. Fuzzy logic systems for engineering: a tutorial. *Proceeding of the IEEE* **83** (3) (1995) 345–377.
- [18] J. S. Jang and C. T. Sun. Neuro-fuzzy modeling and control. *Proceeding of the IEEE* **83** (3) (1995) 378–406.
- [19] H. *Le Reglage Par Logique Floue*. Presses Polytechniques Romandes, 1994.
- [20] J. J. Buckley and H. Ying. Fuzzy Controller theory: Limit theorems for linear fuzzy control rules. *Automatica* **25** (3) (1989) 469–472.
- [21] M. Sugeno and G. T. Kang. Structure Identification of Fuzzy Model. *Fuzzy sets and systems* **28** (1) (1988) 15–33.
- [22] F.H.F. Leung and P. K. S. Tam. Fuzzy model controller for inverted pendulum. *Electronics Letters* **32** (2) (1996) 1683–1685.
- [23] P. Pillay and R. Krishnan. Modeling, simulation and analysis of permanent magnet motor drives. *IEEE Trans. on Industry Applications* **25** (2) (1989) 265–273.
- [24] P. Pillay and R. Krishnan. Modeling of permanent magnet motor drive. *IEEE Trans. on Industrial Electronics* **35** (4) (1988).
- [25] T. H. Liu, C. M. Young and C. H. Liu. Microprocessor-based controller design and simulation for a permanent magnet synchronous motor drive. *IEEE Trans. on Industrial Electronics* **35** (4) (1988) 516–523.
- [26] J. M. Thomas. Motion Control With Permanent Magnet AC Machine. *Proc. of the IEEE* **82** (8) (1994) 1241–1252.